

PTW

Pompy liniowe standardowe dla wody pitnej



PRZEZNACZENIE

Pompy liniowe standardowe przeznaczone są do pompowania wody pitnej.

ZASTOSOWANIE

Pompy liniowe standardowe dla wody pitnej stosowane głównie w układach cyrkulacji wody pitnej, w systemach klimatyzacyjnych i chłodniczych.

ZAKRES UŻYTKOWANIA

Wydajność	do 90 m ³ /h
Wysokość podnoszenia	do 27 m
Ciśnienie robocze	1,0 MPa
Średnica przyłączy	DN25-DN100
Moc silnika	do 2,2 kW
Temperatura czynnika	0 do 90°C

CECHY KONSTRUKCYJNE

część hydrauliczna

- pompa pionowa jednostopniowa z suchym wirnikiem silnika,
- brązowy korpus oraz wirnik pompy ze stali nierdzewnej,
- konstrukcja in-line, demontowalna do góry,
- uszczelnienie mechaniczne - standardowo BAQE,

silnik

- jedno lub trójfazowy asynchroniczny,
- chłodzony powietrzem,
- stałobrotowy,
- wał silnika połączony z wałem pompy za pomocą sztywnego tulejowego sprzęgła.

KLUCZ OZNACZEŃ

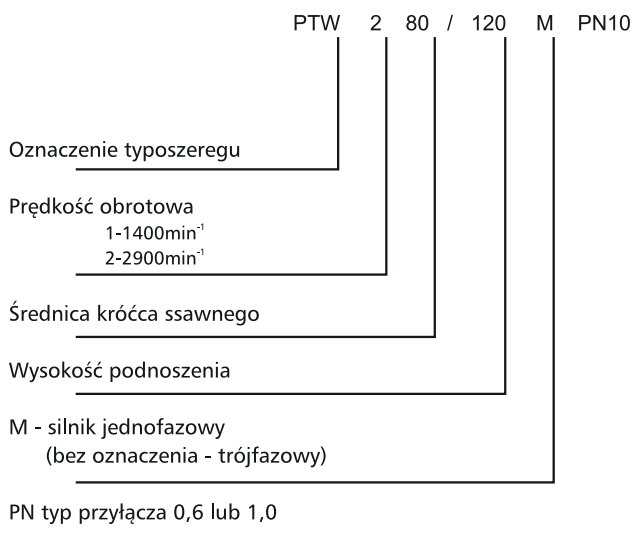

ZALETY

- niskie koszty montażu (prostoliniowy układ rurociągów),
- wydłużony okres żywotności - dzięki wyważonemu hydraulicznie i mechanicznie wirnikowi),
- możliwość współpracy z przetwornicą częstotliwościową,
- niskie zużycie energii,
- wysoka sprawność silników IE2 i IE3,
- brak konieczności obsługi,
- podwyższony komfort i jakość wykonania.

BUDOWA

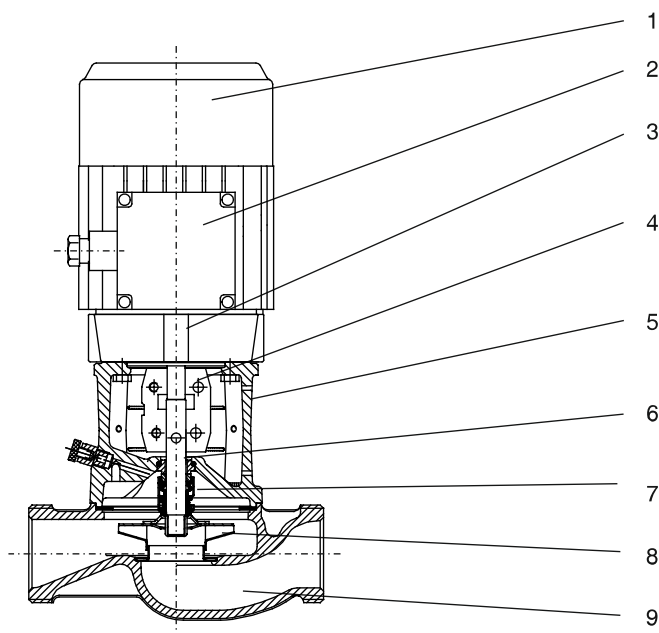

- 1. Silnik pompy
- 2. Puszka zaciskowa
- 3. Wał silnika
- 4. Sprzęgło łukkowe
- 5. Łącznik
- 6. Wał pompy
- 7. Dławnica
- 8. Wirnik pompy
- 9. Korpus pompy

Uszczelnienie

Standardowo w pompach montowane są dławnice BAQE, jednak na specjalne zamówienie lub wyniku specyfikacji tłocznej cieczy montowane są również innego typu uszczelnienie.

Przykładowy rysunek przekrojowy dławnicy typu BAQE

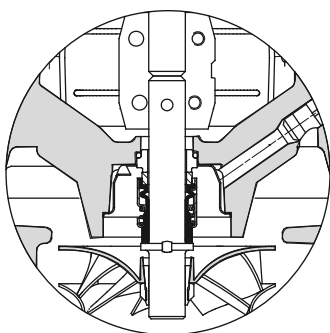

Typ dławnicy	Uszczelnienie wału	Elementy obrotowe	Elementy stałe	Uszczelnienie wtórne
BAQE	B	A	Q	E
AUUE	A	U	U	E
BBQE	B	B	Q	E
BQQE	B	Q	Q	E
BUBE	B	U	B	E
DBUE	D	B	U	E
DQQE	D	Q	Q	E
GQQE	G	Q	Q	E
RUUE	R	U	U	E

POMPY LINIOWE

CHARAKTERYSTYKA

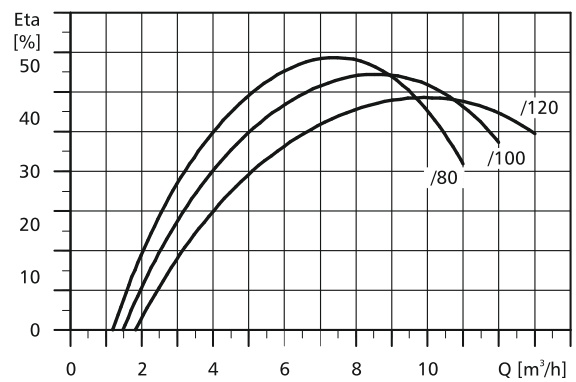
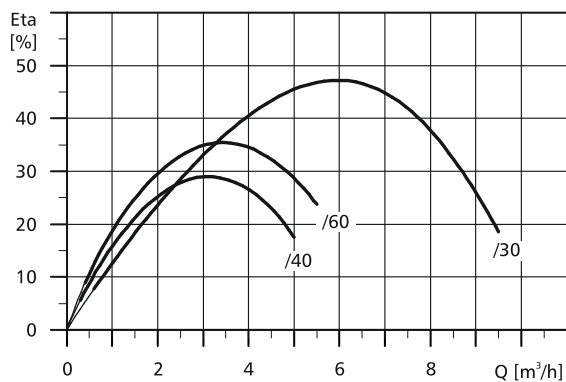
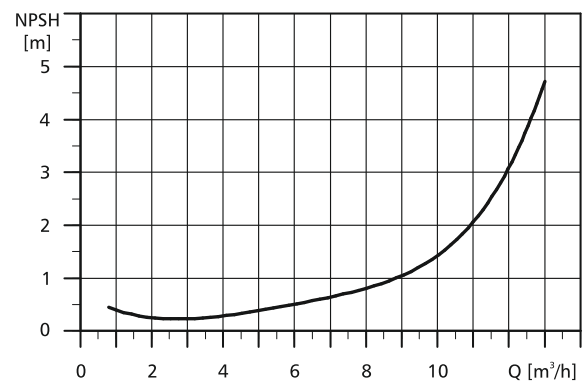
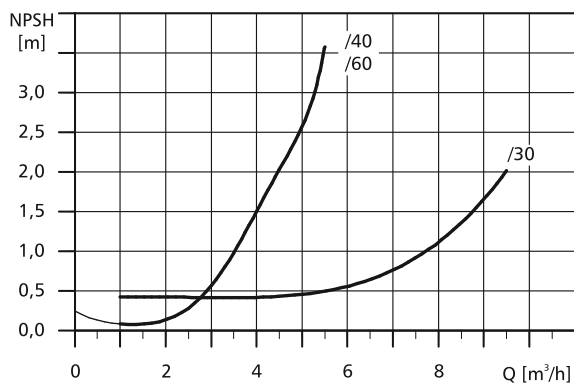
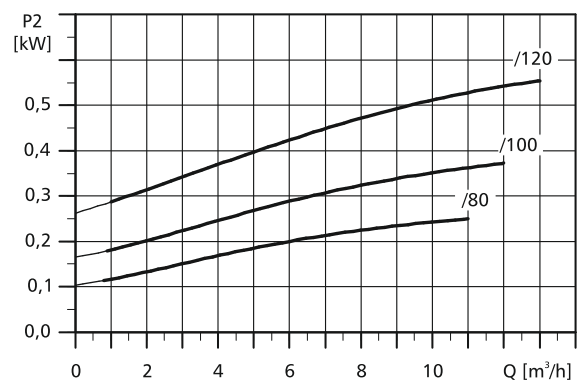
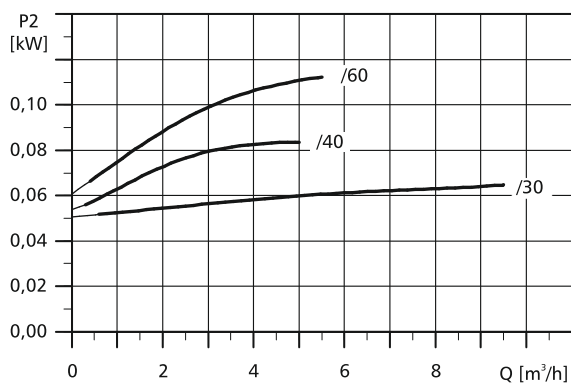
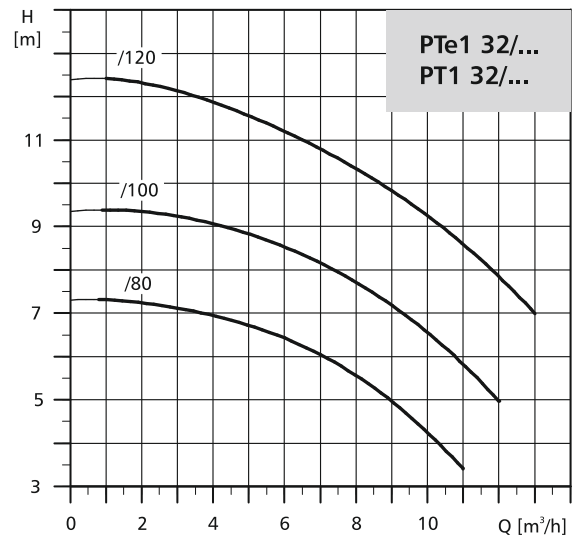
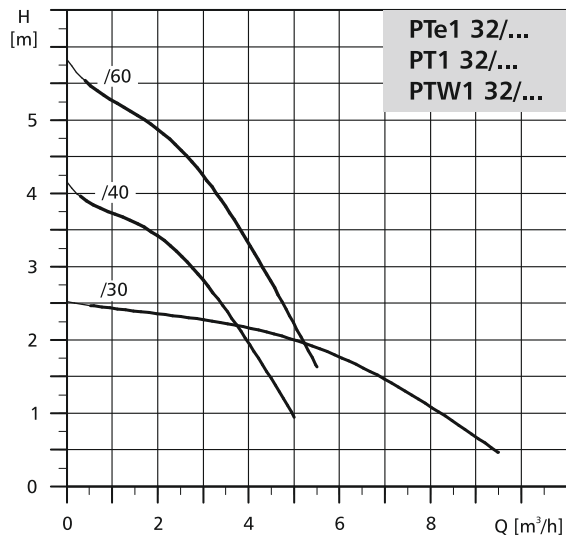

DANE MONTAŻOWE

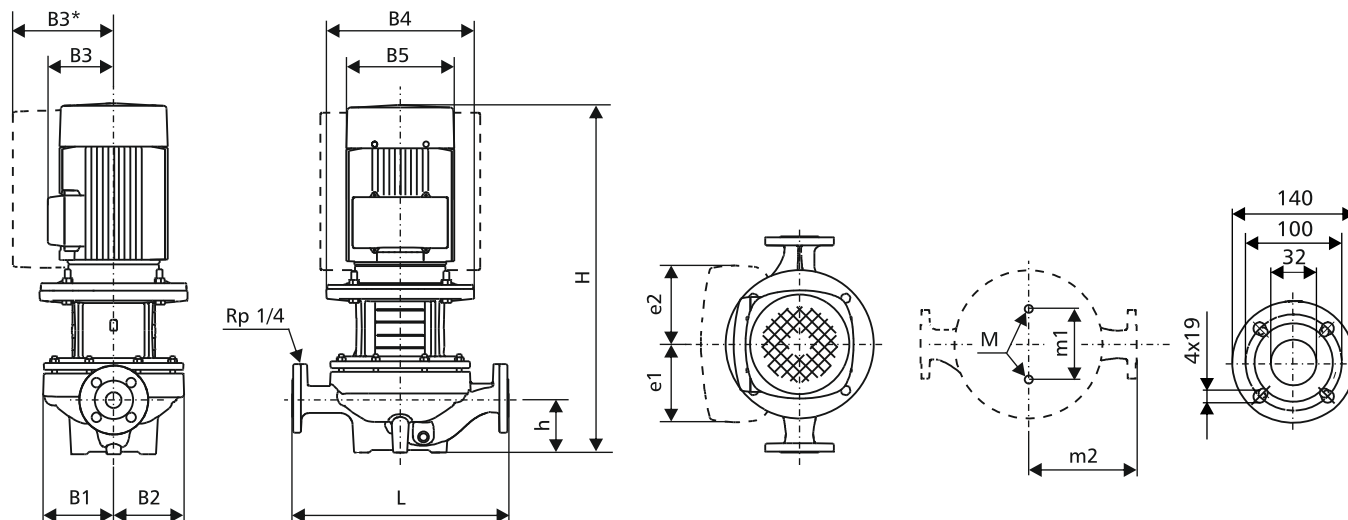

B3* - dotyczy pomp PTe

TYP POMPY	Moc silnika	Wymiary [mm]													Masa [kg]	
		L	H	h	B1	B2	B3	B4	B5	e1	e2	m1	m2	M	PT...	PTW...
PTe1 32/30 M	0,12	220	408	68	75	75	140	-	141	105	105	80	110	M12	21	-
PTe1 32/40 M	0,25	280	395	79	100	100	140	105	141	105	105	80	140	M12	29	-
PTe1 32/60 M	0,25	280	395	79	100	100	140	-	141	105	105	80	140	M12	29	-
PTe1 32/80 M	0,25	340	420	100	125	117	140	170	141	105	105	144	170	M16	36	-
PTe1 32/100 M	0,37	340	420	100	125	117	140	170	141	105	105	144	170	M16	37	-
PTe1 32/120 M	0,55	440	487	100	144	144	140	200	141	105	105	144	220	M16	48	-
PTe1 32/120	0,55	440	537	100	144	144	167	200	178	132	132	144	220	M16	48	-
PT1 32/30 M	0,12	220	416	68	75	75	101	-	118	-	-	80	110	M12	15	17
PT1 32/30	0,12	220	390	68	75	75	101	-	118	-	-	80	110	M12	15	17
PT1 32/40 M	0,18	280	395	79	100	100	133	105	141	-	-	80	140	M12	25	28
PT1 32/40	0,25	280	395	79	100	100	133	105	141	-	-	80	140	M12	25	28
PT1 32/60 M	0,18	280	395	79	100	100	133	-	141	-	-	80	140	M12	25	28
PT1 32/60	0,25	280	395	79	100	100	133	-	141	-	-	80	140	M12	25	28
PT1 32/80 M	0,25	340	420	100	125	117	109	170	141	-	-	144	170	M16	35	-
PT1 32/80	0,25	340	420	100	125	117	109	170	141	-	-	144	170	M16	35	-
PT1 32/100 M	0,37	340	420	100	125	117	109	170	141	-	-	144	170	M16	36	-
PT1 32/100	0,37	340	420	100	125	117	109	170	141	-	-	144	170	M16	36	-
PT1 32/120 M	0,55	440	487	100	144	144	109	200	141	-	-	144	220	M16	49	-
PT1 32/120	0,55	440	487	100	144	144	109	200	141	-	-	144	220	M16	49	-

DANE ELEKTRYCZNE

Moc silnika [kW]	Silniki pomp PTe...			Silniki pomp PT...					
	U [V]	n [min ⁻¹]	In [A]	U [V]	n [min ⁻¹]	η [%]	cos φ	In [A]	In/Ir [A]
0,12	1x200-240	1400	2,2-1,9	1x230/240	1400	53,1	0,99	0,99	2,58
0,12	-	-	-	3x230-240/400-415	1400	54	0,67	0,78/0,45	3,2
0,18	-	-	-	1x230/240	1400	54	0,97	1,62	2,0
0,25	1x200-240	1400	3,0-2,5	1x230/240	1400	57	0,97	2,14	2,2
0,25	-	-	-	3x230-240/400-415	1400	69	0,75-0,65	1,48/0,85	4,0-4,4
0,37	1x200-240	1400	3,1-2,6	1x230/240	1400	62	0,97	2,85	2,4
0,37	-	-	-	3x230-240/400-415	1400	71	0,77-0,67	1,9/1,1	4,0-4,4
0,55	1x200-240	1400	4,4-3,6	1x230/240	1400	66	0,97	4	2,6
0,55	3x380-480	1400	1,5-1,6	3x230-240/400-415	1400	77	0,79-0,7	2,6/1,5	4,3-4,7

Silniki pomp:

PTe - o regulowanej prędkości obrotowej

PT - stałobrotowe

POMPY LINIOWE

CHARAKTERYSTYKA

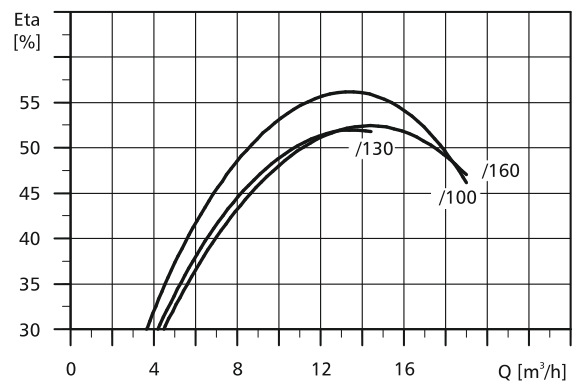
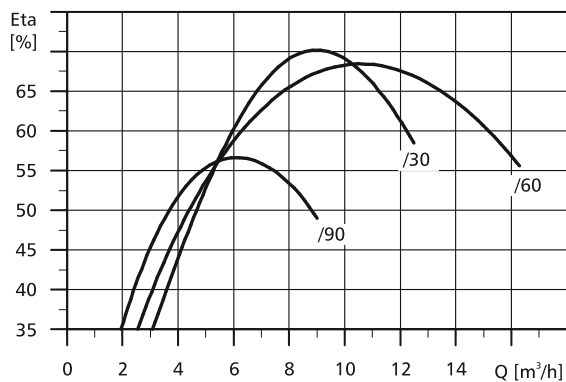
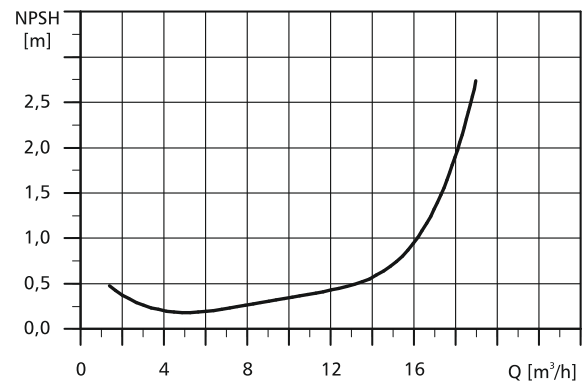
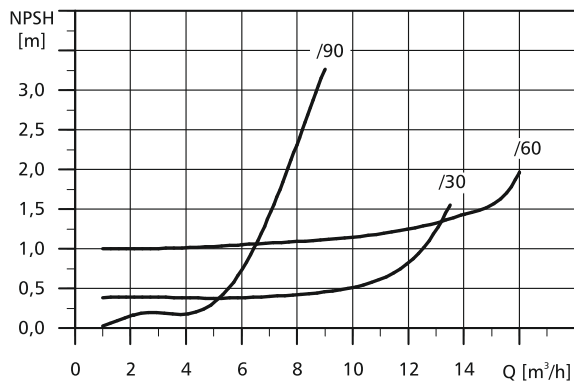
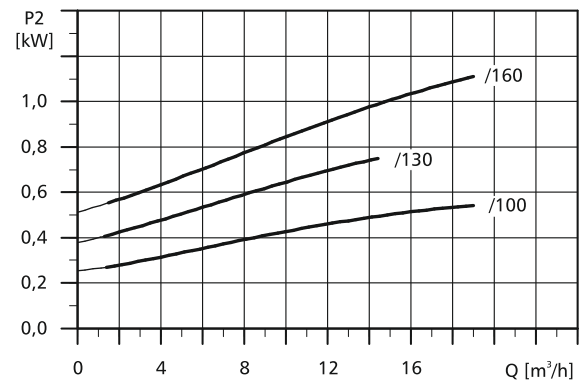
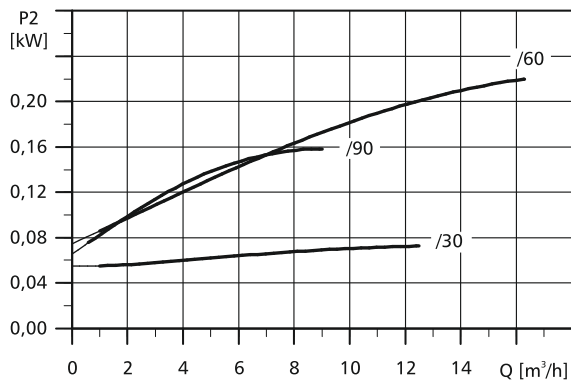
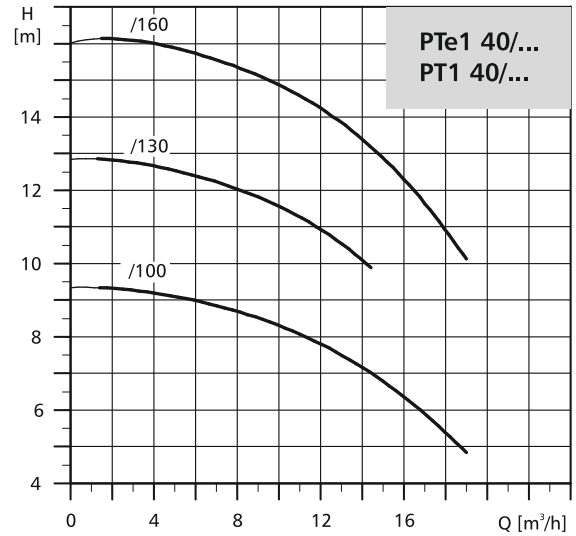
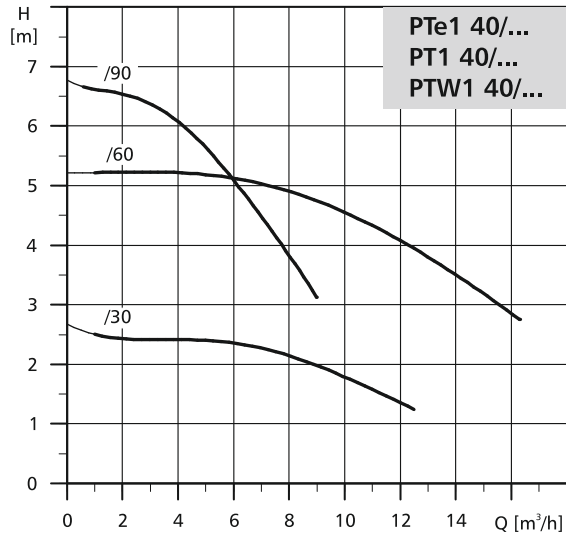

DANE MONTAŻOWE

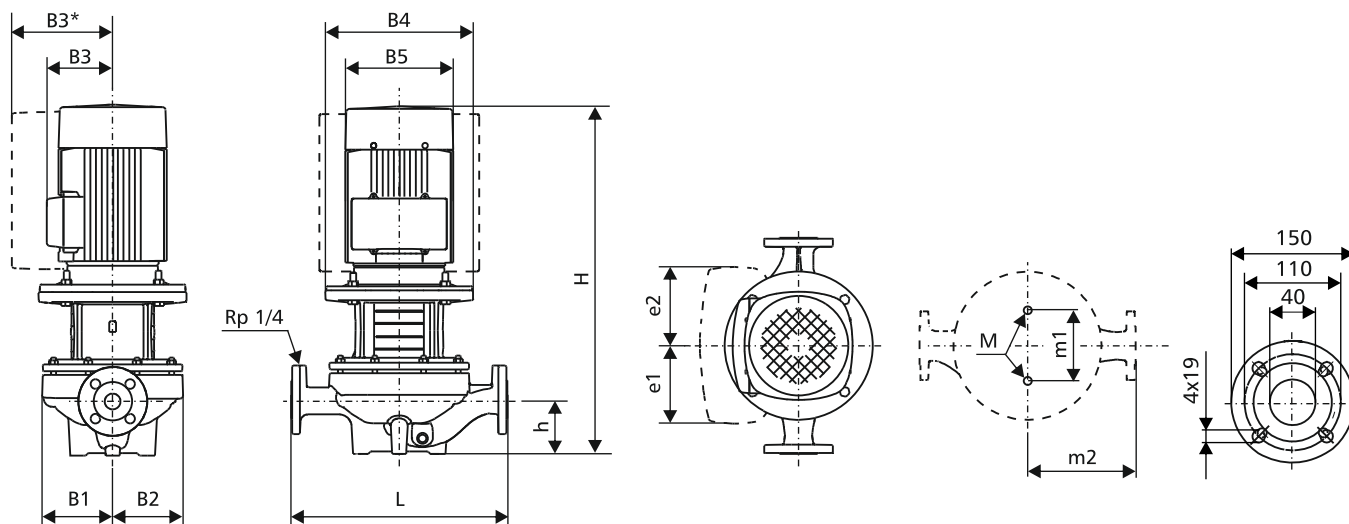

B3* - dotyczy pomp PTe

TYP POMPY	Moc silnika	Wymiary [mm]													Masa [kg]	
		L	H	h	B1	B2	B3	B4	B5	e1	e2	m1	m2	M	PT...	PTW...
PTe1 40/30 M	0,12	250	411	67	85	75	140	-	141	105	105	120	125	M12	23	-
PTe1 40/60 M	0,25	250	389	75	100	100	140	-	141	105	105	120	125	M12	27	-
PTe1 40/90 M	0,25	320	388	68	100	100	140	105	141	105	105	120	160	M12	32	-
PTe1 40/100 M	0,55	340	507	100	130	117	140	200	141	105	105	144	170	M16	42	-
PTe1 40/100	0,55	340	547	100	130	117	167	200	178	132	132	144	170	M16	42	-
PTe1 40/130 M	0,75	440	499	110	149	144	140	200	141	105	105	144	220	M16	58	-
PTe1 40/130	0,75	440	549	110	149	144	167	200	178	132	132	144	220	M16	58	-
PTe1 40/160	1,1	440	549	110	149	144	167	200	178	132	132	144	220	M16	64	-
PT1 40/30 M	0,12	250	419	67	85	75	101	-	118	-	-	120	125	M12	17	20
PT1 40/30	0,12	250	393	67	85	75	101	-	118	-	-	120	125	M12	17	20
PT1 40/60 M	0,25	250	389	75	100	100	133	-	141	-	-	120	125	M12	22	25
PT1 40/60	0,25	250	389	75	100	100	109	-	141	-	-	120	125	M12	22	25
PT1 40/90 M	0,18	320	388	68	100	100	133	105	141	-	-	120	160	M12	28	31
PT1 40/90	0,25	320	398	68	100	100	133	105	141	-	-	120	160	M12	28	31
PT1 40/100 M	0,55	340	497	100	130	117	109	200	141	-	-	144	170	M16	41	-
PT1 40/100	0,55	340	497	100	130	117	109	200	141	-	-	144	170	M16	41	-
PT1 40/130 M	0,75	440	549	110	149	144	110	200	178	-	-	144	220	M16	47	-
PT1 40/130	0,75	440	549	110	149	144	110	200	178	-	-	144	220	M16	47	-
PT1 40/160 M	1,1	440	589	110	149	144	110	200	178	-	-	144	220	M16	53	-
PT1 40/160	1,1	440	589	110	149	144	110	200	178	-	-	144	220	M16	53	-

DANE ELEKTRYCZNE

Moc silnika [kW]	Silniki pomp PTe...			Silniki pomp PT...					
	U [V]	n [min ⁻¹]	In [A]	U [V]	n [min ⁻¹]	η [%]	cos φ	In [A]	In/Ir [A]
0,12	1x200-240	1400	2,2-1,9	1x230/240	1400	53,1	0,99	0,99	2,58
0,12	-	-	-	3x230-240/400-415	1400	54	0,67	0,78/0,45	3,2
0,18	-	-	-	1x230/240	1400	54	0,97	1,62	2,0
0,25	1x200-240	1400	3,0-2,5	1x230/240	1400	57	0,97	2,14	2,2
0,25	-	-	-	3x230-240/400-415	1400	69	0,75-0,65	1,48/0,85	4,0-4,4
0,55	1x200-240	1400	4,0-3,6	1x230/240	1400	66	0,97	4	2,6
0,55	3x380-480	1400	1,5-1,6	3x230-240/400-415	1400	77	0,79-0,7	2,6/1,5	4,3-4,7
0,75	1x200-240	1400	5,3-4,85	1x230/240	1400	71	0,96	5,45	3,2
0,75	3x380-480	1400	1,8-1,9	3x230-240/400-415	1400	82,5	0,76-0,71	3,3/1,9	6,6-1,2
1,1	-	-	-	1x230/240	1400	75	0,96	7	3,9
1,1	3x380-480	1400	2,5-2,2	3x230-240/400-415	1400	84,1	0,71-0,64	4,85/2,0	8,2-9,0

Silniki pomp:

PTe - o regulowanej prędkości obrotowej

PT - stałobrotowe

POMPY LINIOWE

CHARAKTERYSTYKA

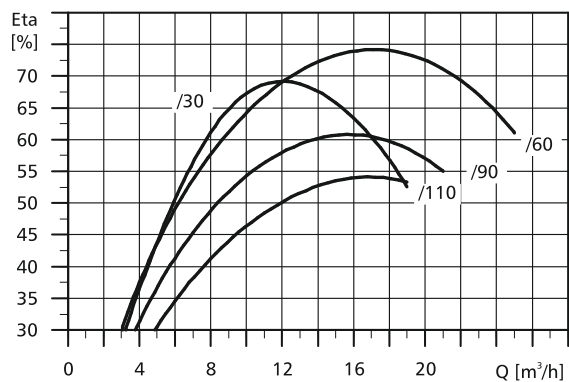
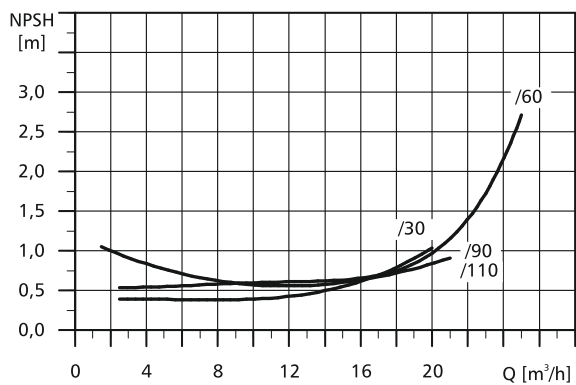
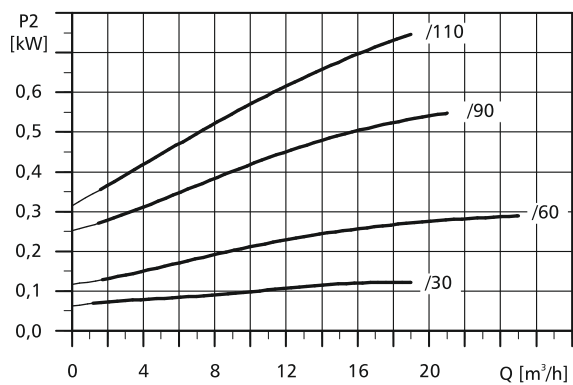
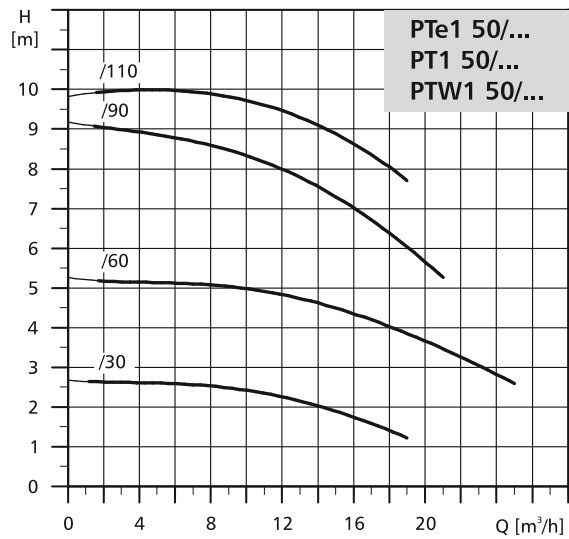

DANE MONTAŻOWE

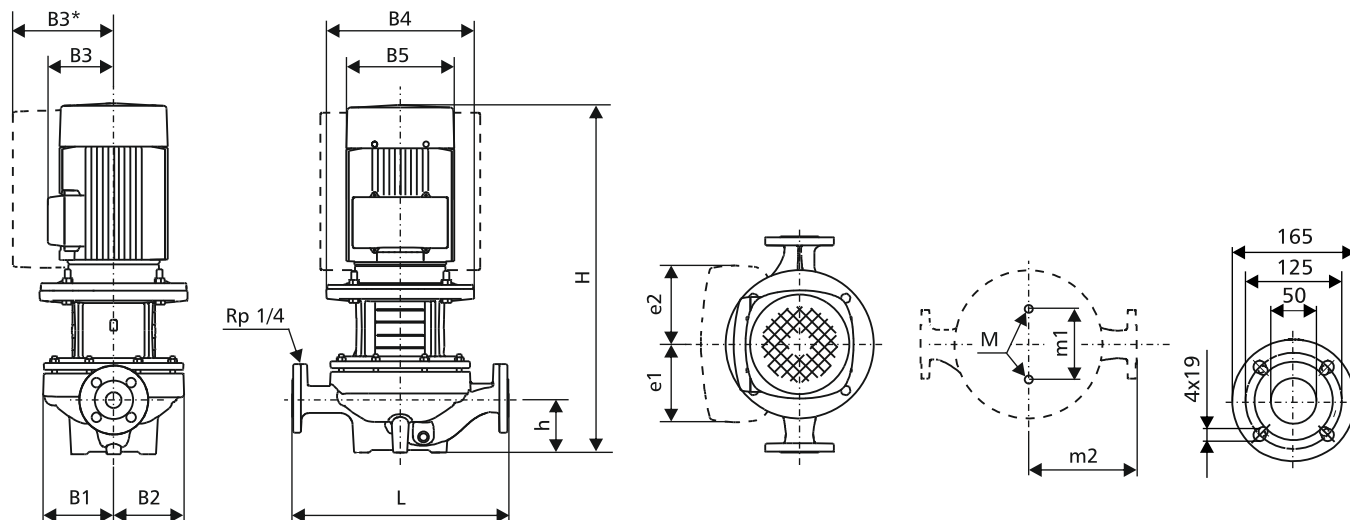

B3* - dotyczy pomp PTe

TYP POMPY	Moc silnika	Wymiary [mm]													Masa [kg]	
		L	H	h	B1	B2	B3	B4	B5	e1	e2	m1	m2	M	PT...	PTW...
PTe1 50/30 M	0,25	280	408	82	75	90	140	-	141	105	105	120	140	M12	30	-
PTe1 50/60 M	0,37	280	400	82	110	100	140	-	141	105	105	120	140	M12	28	-
PTe1 50/90 M	0,55	340	507	115	133	119	140	200	141	105	105	144	170	M16	44	-
PTe1 50/90	0,55	340	557	115	133	119	167	200	178	132	132	144	170	M16	44	-
PTe1 50/110 M	0,75	440	513	115	180	164	140	200	141	105	105	144	220	M16	66	-
PTe1 50/110	0,75	440	563	115	180	164	167	200	178	132	132	144	220	M16	66	-
PT1 50/30 M	0,18	280	408	82	75	90	133	-	141	-	-	120	140	M12	24	27
PT1 50/30	0,25	280	416	82	75	90	133	-	141	-	-	120	140	M12	24	27
PT1 50/60 M	0,37	280	452	82	110	100	133	-	141	-	-	120	140	M12	25	28
PT1 50/60	0,37	280	400	82	110	100	109	-	141	-	-	120	140	M12	25	28
PT1 50/90 M	0,55	340	507	115	133	119	109	200	141	-	-	144	170	M16	43	-
PT1 50/90	0,55	340	507	115	133	119	109	200	141	-	-	144	170	M16	43	-
PT1 50/110 M	0,75	440	553	115	180	164	110	200	178	-	-	144	220	M16	55	-
PT1 50/110	0,75	440	553	115	180	164	110	200	178	-	-	144	220	M16	55	-

DANE ELEKTRYCZNE

Moc silnika [kW]	Silniki pomp PTe...			Silniki pomp PT...					
	U [V]	n [min ⁻¹]	In [A]	U [V]	n [min ⁻¹]	η [%]	cos φ	In [A]	In/Ir [A]
0,18	-	-	-	1x230/240	1400	54	0,97	1,62	2,0
0,25	1x200-240	1400	3,0-2,5	-	-	-	-	-	-
0,25	-	-	-	3x230-240/400-415	1400	69	0,75-0,65	1,48/0,85	4,0-4,4
0,37	1x200-240	1400	3,1-2,6	1x230/240	1400	62	0,97	2,85	2,4
0,37	-	-	-	3x230-240/400-415	1400	71	0,77-0,67	1,9/1,1	4,0-4,4
0,55	1x200-240	1400	4,0-3,6	1x230/240	1400	66	0,97	4	2,6
0,55	3x380-480	1400	1,5-1,6	3x230-240/400-415	1400	77	0,79-0,7	2,6/1,5	4,3-4,7
0,75	1x200-240	1400	5,3-4,85	1x230/240	1400	71	0,96	5,45	3,2
0,75	3x380-480	1400	1,8-1,9	3x230/240/400-415	1400	82,5	0,76-0,71	3,3/1,9	6,6-1,2

Silniki pomp:

PTe - o regulowanej prędkości obrotowej

PT - stałobrotowe

POMPY LINIOWE

CHARAKTERYSTYKA

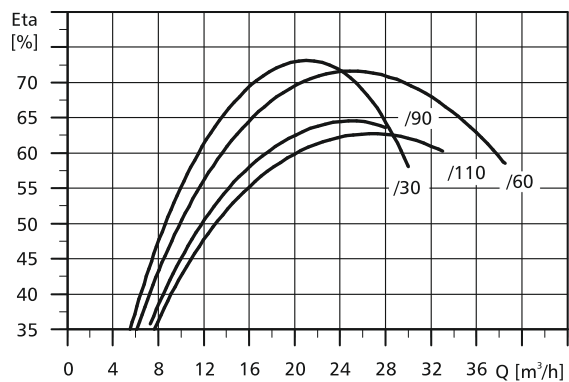
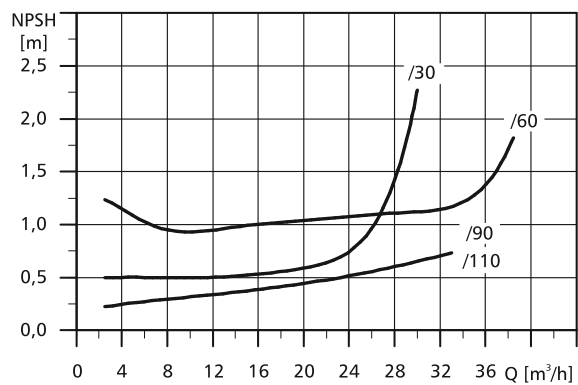
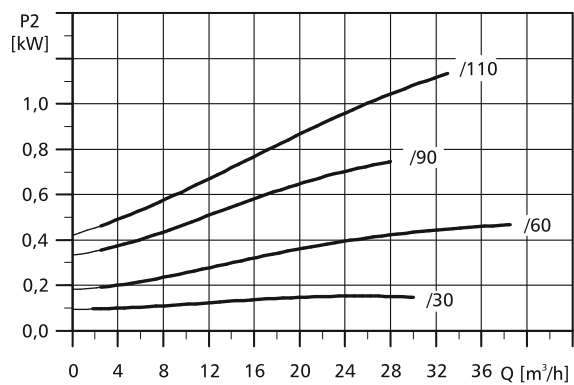
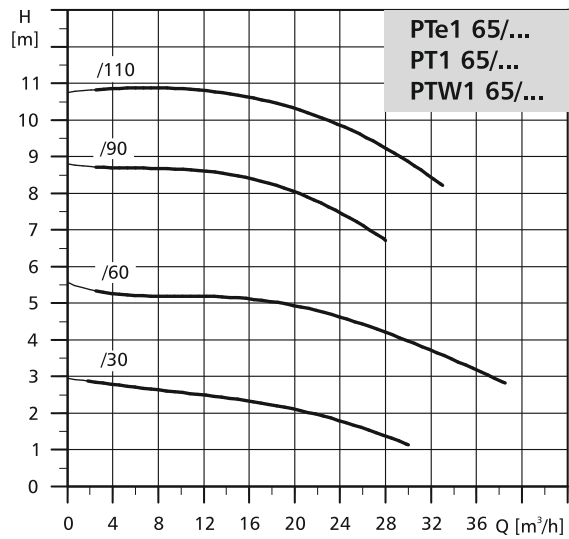

DANE MONTAŻOWE

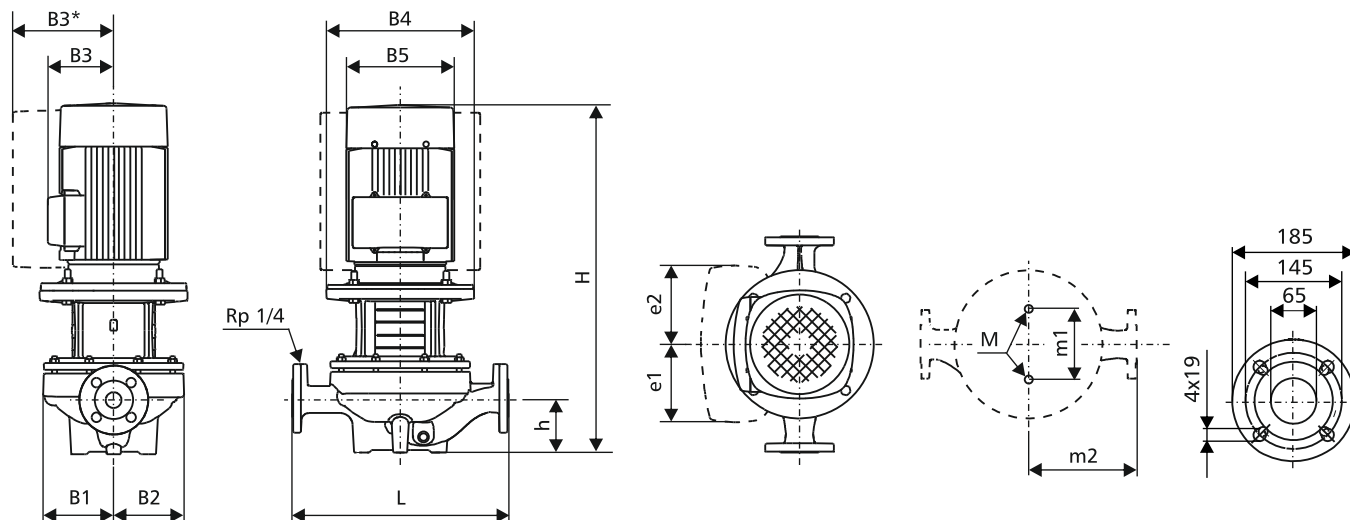

B3* - dotyczy pomp PTe

TYP POMPY	Moc silnika	Wymiary [mm]													Masa [kg]	
		L	H	h	B1	B2	B3	B4	B5	e1	e2	m1	m2	M	PT...	PTW...
PTe1 65/30 M	0,25	340	423	97	125	100	140	-	141	105	105	160	170	M16	37	-
PTe1 65/60 M	0,55	340	475	97	125	100	140	-	141	105	105	160	170	M16	36	-
PTe1 65/60	0,55	340	525	97	125	100	167	-	178	132	132	160	170	M16	36	-
PTe1 65/90 M	0,75	360	508	105	142	124	140	200	141	105	105	144	180	M16	57	-
PTe1 65/90	0,75	360	558	105	142	124	167	200	178	105	105	144	180	M16	57	-
PTe1 65/110	1,1	475	572	125	178	164	167	200	178	132	132	144	238	M16	74	-
PT1 65/30 M	0,25	340	423	97	100	125	133	-	141	-	-	160	170	M16	33	37
PT1 65/30	0,25	340	423	97	100	125	109	-	141	-	-	160	170	M16	33	37
PT1 65/60 M	0,55	340	475	97	100	125	133	-	141	-	-	160	170	M16	33	37
PT1 65/60	0,55	340	475	97	100	125	109	-	141	-	-	160	170	M16	33	37
PT1 65/90 M	0,75	360	508	105	142	124	109	200	141	-	-	144	180	M16	46	-
PT1 65/90	0,75	360	508	105	142	124	109	200	178	-	-	144	180	M16	46	-
PT1 65/110 M	1,1	475	587	125	178	164	170	200	200	-	-	144	238	M16	63	-
PT1 65/110	1,1	475	572	125	178	164	170	200	200	-	-	144	238	M16	63	-

DANE ELEKTRYCZNE

Moc silnika [kW]	Silniki pomp PTe...			Silniki pomp PT...					
	U [V]	n [min ⁻¹]	In [A]	U [V]	n [min ⁻¹]	η [%]	cos φ	In [A]	In/Ir [A]
0,25	1x200-240	1400	3,0-2,5	1x230/240	1400	57	0,97	2,14	2,2
0,25	-	-	-	3x230-240/400-415	1400	69	0,75-0,65	1,48/0,85	4,0-4,4
0,55	1x200-240	1400	4,0-3,6	1x230/240	1400	66	0,97	4	2,6
0,55	3x380-480	1400	11-9,0	3x230-240/400-415	1400	77	0,79-0,7	2,6/1,5	4,3-4,7
0,75	1x200-240	1400	5,3-4,85	1x230/240	1400	71	0,96	5,45	3,2
0,75	3x380-480	1400	15,0-12,0	3x230-240/400-415	1400	82,5	0,76-0,71	3,3/1,9	6,6-1,2
1,1	-	-	-	1x230/240	1400	75	0,96	7	3,9
1,1	3x380-480	1400	2,5-2,2	3x230-240/400-415	1400	84,1	0,71-0,64	4,85/2,0	8,2-9,0

Silniki pomp:

PTe - o regulowanej prędkości obrotowej

PT - stałobrotowe

POMPY LINIOWE

CHARAKTERYSTYKA

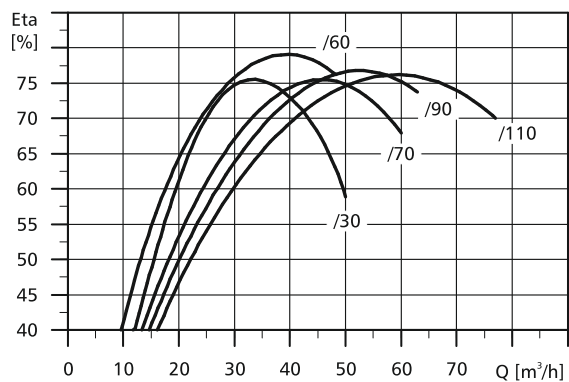
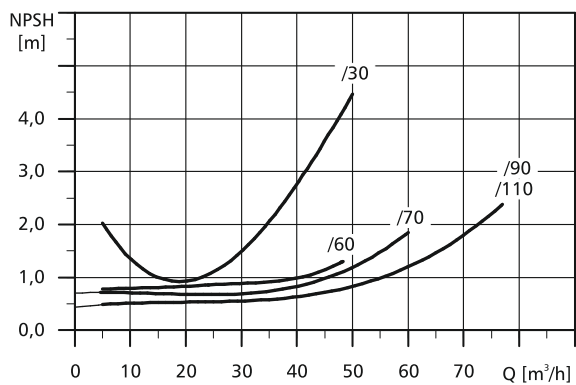
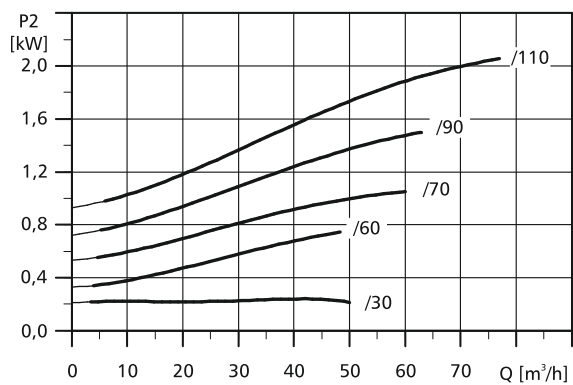
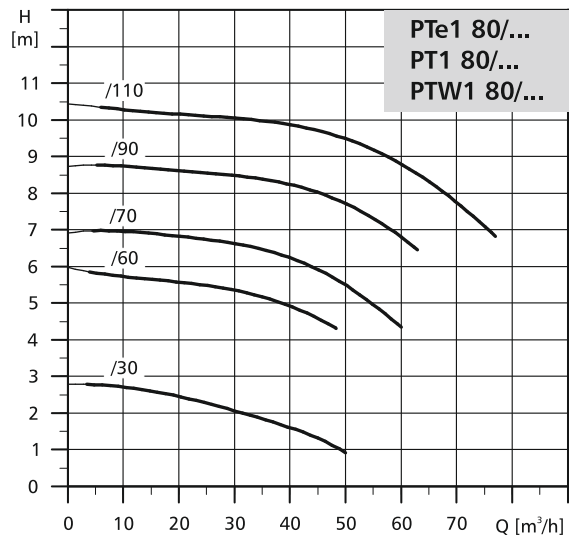

DANE MONTAŻOWE

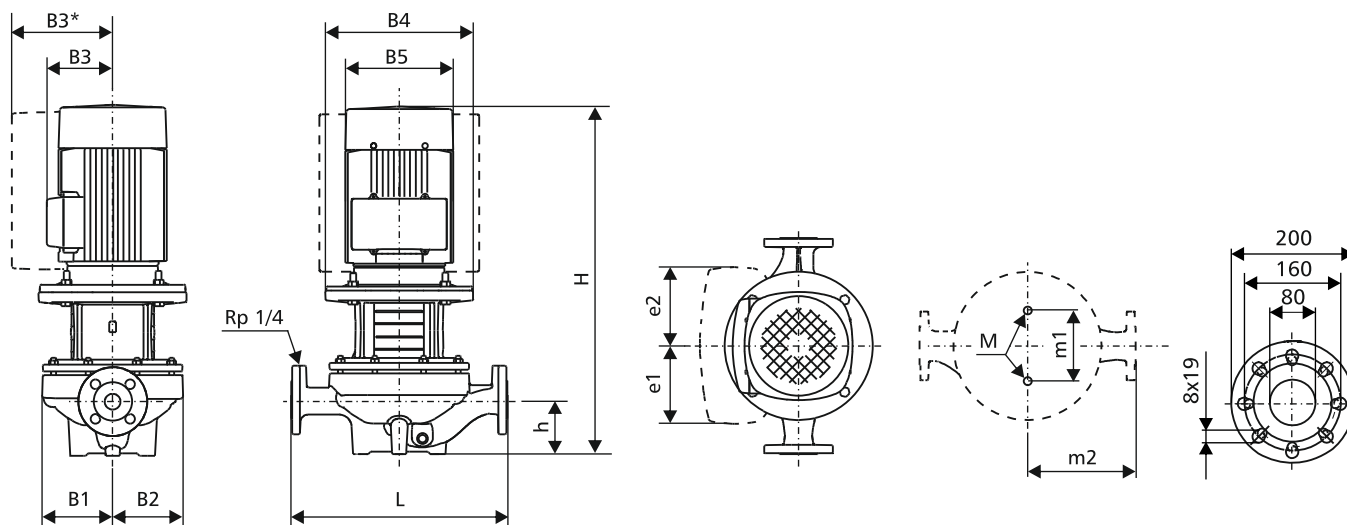

B3* - dotyczy pomp PTe

TYP POMPY	Moc silnika	Wymiary [mm]													Masa [kg]	
		L	H	h	B1	B2	B3	B4	B5	e1	e2	m1	m2	M	PT...	PTW...
PTe1 80/30 M PN6	0,37	360	461	107	130	100	140	-	141	105	105	160	180	M16	41	-
PTe1 80/30 M PN10	0,37	360	461	107	130	100	140	-	141	105	105	160	180	M16	41	-
PTe1 80/60 M PN6	0,75	360	491	107	135	100	140	-	141	105	105	160	180	M16	50	-
PTe1 80/60 M PN10	0,75	360	491	107	135	100	140	-	141	105	105	160	180	M16	50	-
PTe1 80/60 PN6	0,75	360	541	107	135	100	167	-	178	132	132	160	180	M16	50	-
PTe1 80/60 PN10	0,75	360	541	107	135	100	167	-	178	132	132	160	180	M16	50	-
PTe1 80/70	1,1	440	572	115	176	144	167	200	178	132	132	144	220	M16	74	-
PTe1 80/90	1,5	440	612	115	176	144	167	200	178	132	132	144	220	M16	75	-
PTe1 80/110	2,2	440	654	115	176	144	177	250	198	132	132	144	220	M16	84	-
PT1 80/30 M PN6	0,37	360	513	107	130	100	133	-	142	-	-	160	180	M16	37	41
PT1 80/30 M PN10	0,37	360	513	107	130	100	133	-	142	-	-	160	180	M16	37	41
PT1 80/30 PN6	0,37	360	461	107	130	100	109	-	141	-	-	160	180	M16	37	41
PT1 80/30 PN10	0,37	360	461	107	130	100	109	-	141	-	-	160	180	M16	37	41
PT1 80/60 M PN6	0,75	360	551	107	135	100	139	-	178	-	-	160	180	M16	37	41
PT1 80/60 M PN10	0,75	360	551	107	135	100	139	-	178	-	-	160	180	M16	37	41
PT1 80/60 PN6	0,75	360	541	107	135	100	110	-	178	-	-	160	180	M16	37	41
PT1 80/60 PN10	0,75	360	541	107	135	100	110	-	178	-	-	160	180	M16	37	41
PT1 80/70 M	1,1	440	612	115	176	144	110	200	178	-	-	144	220	M16	67	-
PT1 80/70	1,1	440	612	115	176	144	110	200	178	-	-	144	220	M16	67	-
PT1 80/90 M	1,5	440	612	115	176	144	110	200	178	-	-	144	220	M16	70	-
PT1 80/90	1,5	440	612	115	176	144	110	200	178	-	-	144	220	M16	70	-
PT1 80/110	2,2	440	654	115	176	144	120	250	198	-	-	144	220	M16	73	-

DANE ELEKTRYCZNE

Moc silnika [kW]	Silniki pomp PTe...			Silniki pomp PT...					
	U [V]	n [min ⁻¹]	In [A]	U [V]	n [min ⁻¹]	η [%]	cos φ	In [A]	In/Ir [A]
0,37	1x200-240	1400	3,1-2,6	1x230/240	1400	62	0,97	2,85	2,4
0,37	-	-	-	3x230-240/400-415	1400	71	0,77-0,67	1,9/1,1	4,0-4,4
0,75	1x200-240	1400	5,3-4,85	1x230/240	1400	71	0,96	5,45	3,2
0,75	3x380-480	1400	1,8-1,9	3x230-240/400-415	1400	82,5	0,76-0,71	3,3/1,9	6,6-1,2
1,1	-	-	-	1x230/240	1400	75	0,96	7	3,9
1,1	3x380-480	1400	2,5-2,2	3x230-240/400-415	1400	84,1	0,71-0,64	4,85/2,0	8,2-9,0
1,5	-	-	-	1x230/240	1400	74	0,97	9,9	4,7
1,5	3x380-480	1400	3,3-2,9	3x230-240/400-415	1400	85,3	0,75-0,68	6,15-6,3/3,55-3,65	7,3-7,9
2,2	3x380-480	1400	4,6-3,8	3x230-240/400-415	1400	86,7	0,79-0,73	8,5/4,5	6,0-6,6

Silniki pomp:

PTe - o regulowanej prędkości obrotowej

PT - stałobrotowe

POMPY LINIOWE

CHARAKTERYSTYKA

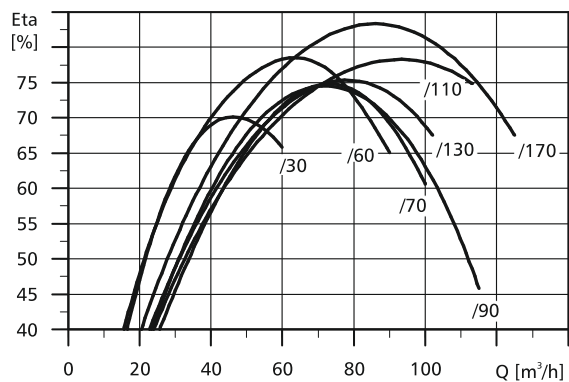
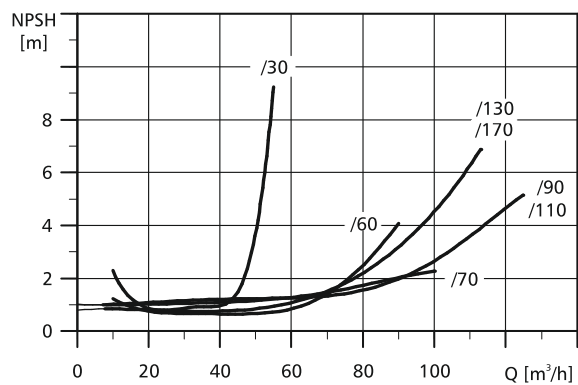
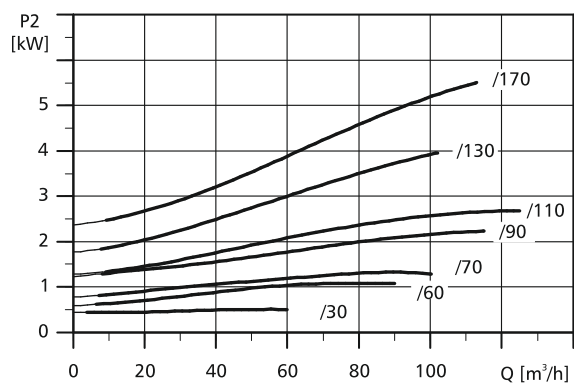
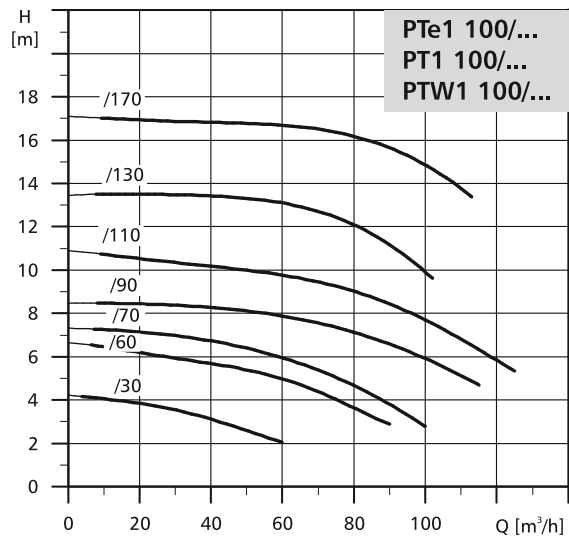

DANE MONTAŻOWE

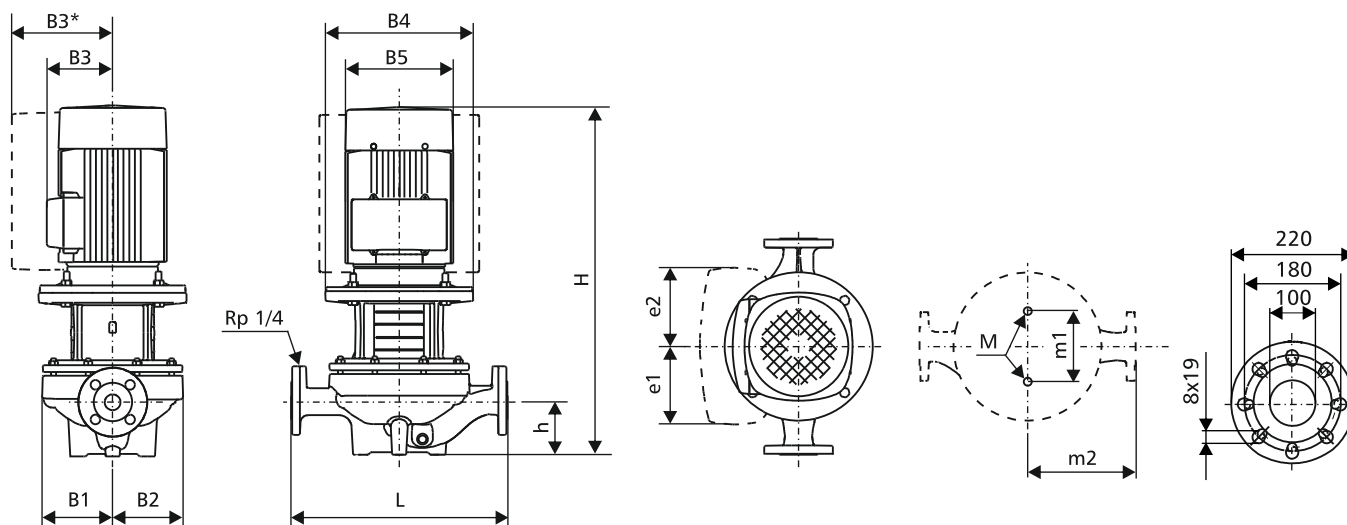

B3* - dotyczy pomp PTe

TYP POMPY	Moc silnika	Wymiary [mm]													Masa [kg]	
		L	H	h	B1	B2	B3	B4	B5	e1	e2	m1	m2	M	PT...	PTW...
PTe1 100/30 M PN6	0,55	450	525	122	175	125	140	-	141	105	105	200	225	M16	43	43
PTe1 100/30 M PN10	0,55	450	525	122	175	125	140	-	141	105	105	200	225	M16	43	43
PTe1 100/30 PN6	0,55	450	575	122	175	125	167	-	178	132	132	200	225	M16	43	43
PTe1 100/30 PN10	0,55	450	575	122	175	125	167	-	178	132	132	200	225	M16	43	43
PTe1 100/60 PN6	1,1	450	585	122	175	125	167	-	178	132	132	200	225	M16	63	63
PTe1 100/60 PN10	1,1	450	585	122	190	125	167	-	178	132	132	200	225	M16	63	63
PTe1 100/70	1,5	550	634	140	190	151	167	200	178	132	132	230	250	M16	100	100
PTe1 100/90	2,2	550	676	140	190	151	177	200	198	132	132	230	275	M16	109	-
PTe1 100/110	3,0	550	676	140	190	151	177	200	198	132	132	230	275	M16	106	-
PTe1 100/130	4,0	550	773	140	201	173	188	250	220	145	145	230	275	M16	144	-
PTe1 100/170	5,5	550	796	140	201	173	213	300	260	145	145	230	275	M16	155	-
PT1 100/30 M PN6	0,55	450	525	122	175	125	133	-	141	-	-	200	225	M16	41	45
PT1 100/30 M PN10	0,55	450	525	122	175	125	133	-	141	-	-	200	225	M16	41	45
PT1 100/30 PN6	0,55	450	525	122	175	125	109	-	141	-	-	200	225	M16	41	45
PT1 100/30 PN10	0,55	450	525	122	175	125	109	-	141	-	-	200	225	M16	41	45
PT1 100/60 M PN6	1,1	450	625	122	175	125	139	-	178	-	-	200	225	M16	52	58
PT1 100/60 M PN10	1,1	450	625	122	175	125	139	-	178	-	-	200	225	M16	52	58
PT1 100/60 PN6	1,1	450	625	122	175	125	110	-	178	-	-	200	225	M16	52	58
PT1 100/60 PN10	1,1	450	625	122	175	125	110	-	178	-	-	200	225	M16	52	58
PT1 100/70 M	1,5	550	634	140	190	151	110	200	178	-	-	230	250	M16	95	-
PT1 100/70	1,5	550	634	140	190	151	110	200	178	-	-	230	250	M16	95	-
PT1 100/90	2,2	550	676	140	190	173	120	200	198	-	-	230	275	M16	97	-
PT1 100/110	3,0	550	676	140	190	173	120	200	198	-	-	230	275	M16	107	-
PT1 100/130	4,0	550	773	140	201	173	134	250	220	-	-	230	275	M16	139	-
PT1 100/170	5,5	550	796	140	201	173	159	300	260	-	-	230	275	M16	168	-

DANE ELEKTRYCZNE

Moc silnika [kW]	Silniki pomp PTe...			Silniki pomp PT...					
	U [V]	n [min ⁻¹]	In [A]	U [V]	n [min ⁻¹]	η [%]	cos φ	In [A]	In/Ir [A]
0,55	1x200-240	1400	4,0-3,6	1x230/240	1400	66	0,97	4	2,6
0,55	3x380-480	1400	1,5-1,6	3x230-240/400-415	1400	77	0,77-0,67	2,6/1,5	4,3-4,7
1,1	-	-	-	1x230/240	1400	75	0,96	7	3,9
1,1	3x380-480	1400	2,5-2,2	3x230-240/400-415	1400	84,1	0,71-0,64	4,85/2,0	8,2-9,0
1,5	-	-	-	1x230/240	1400	74	0,97	9,9	4,7
1,5	3x380-480	1400	3,3-2,9	3x230-240/400-415	1400	85,3	0,75-0,68	6,15-6,3/3,55-3,65	7,3-7,9
2,2	3x380-480	1400	4,6-3,8	3x230-240/400-415	1400	86,7	0,79-0,73	8,5/4,5	6,0-6,6
3,0	3x380-480	1400	6,2-5,0	3x230-240/400-415	1400	87,7	0,82-0,76	11,0/6,3	7,0-7,7
4,0	3x380-480	1400	8,1-6,6	3x230-240/400-415	1400	88,6	0,75-0,68	16,2/9,3	7,9-8,7
5,5	3x380-480	1400	11-9,0	3x230-240/400-415	1400	89,6	0,86-0,80	11,0-11,0/6,35-6,35	7,0-7,6

Silniki pomp:

PTe - o regulowanej prędkości obrotowej

PT - stałobrotowe

POMPY LINIOWE

CHARAKTERYSTYKA

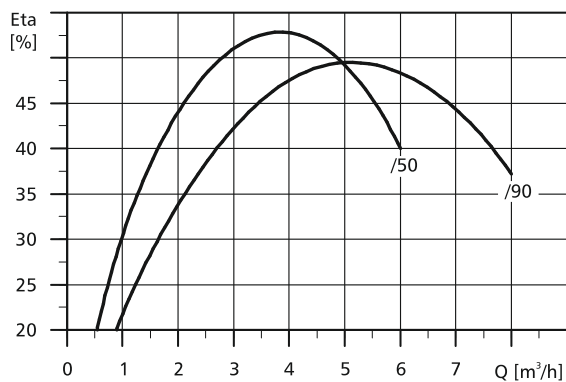
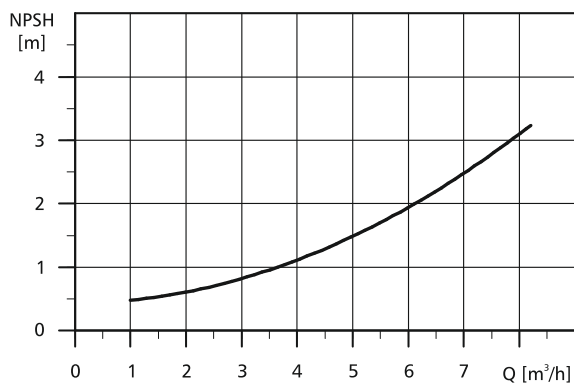
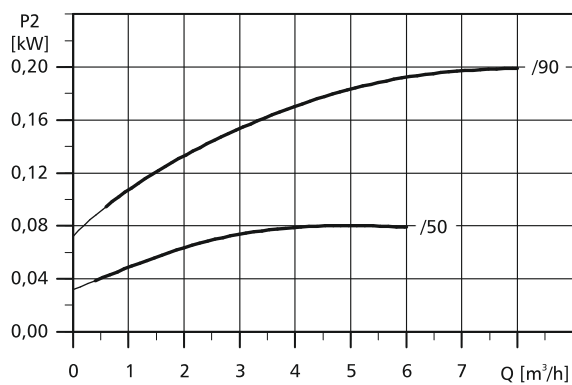
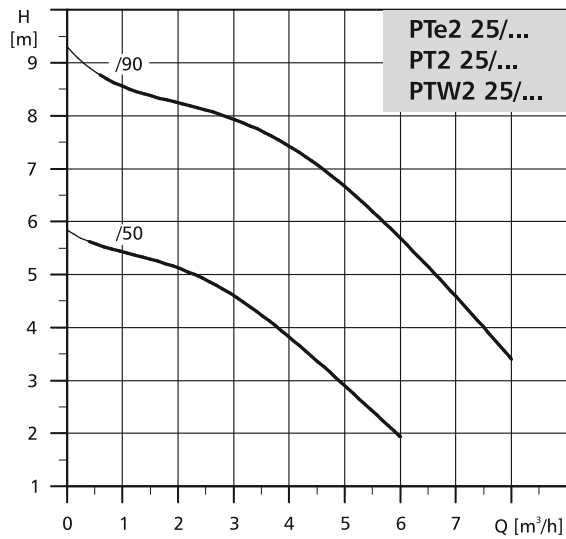

DANE MONTAŻOWE

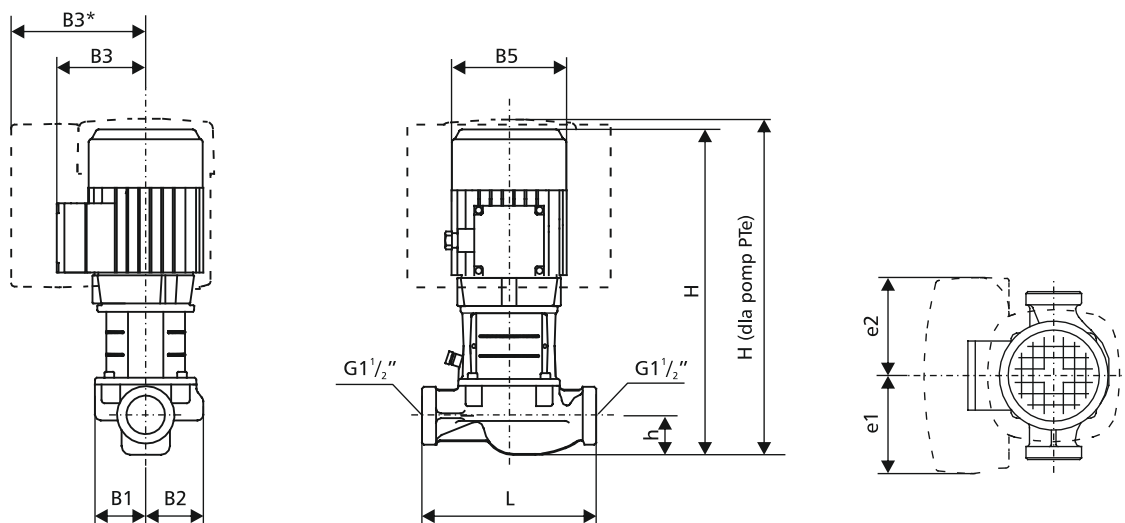

B3* - dotyczy pomp PTe

TYP POMPY	Moc silnika	Wymiary [mm]													Masa [kg]	
		L	H	h	B1	B2	B3	B4	B5	e1	e2	m1	m2	M	PT...	PTW...
PTe2 25/50 M	0,12	180	334	25	54	52	140	-	141	105	105	-	-	-	11	-
PTe2 25/90 M	0,25	180	334	25	54	52	140	-	141	105	105	-	-	-	11	-
PT2 25/50 M	0,12	180	323	25	54	52	101	-	118	-	-	-	-	-	7	8
PT2 25/50	0,12	180	323	25	54	52	101	-	118	-	-	-	-	-	7	8
PT2 25/90 M	0,25	180	353	25	54	52	111	-	139	-	-	-	-	-	8	9
PT2 25/90	0,25	180	323	25	54	52	101	-	118	-	-	-	-	-	8	8

DANE ELEKTRYCZNE

Moc silnika [kW]	Silniki pomp PTe...			Silniki pomp PT...					
	U [V]	n [min ⁻¹]	In [A]	U [V]	n [min ⁻¹]	η [%]	cos φ	In [A]	In/Ir [A]
0,12	1x200-240	2900	2,2-1,9	1x230-240	2900	65	0,99	1,05	3,2-3,6
0,12	-	-	-	3x230-240/400-415	2900	71	0,8-0,72	0,59-0,34	4,2-4,6
0,25	1x200-240	2900	3,0-2,5	1x230-240	2900	58	0,99	2,05/2	-
0,25	-	-	-	3x230-240/400-415	2900	73	0,81-0,72	1,18/0,68	4,0-4,4

Silniki pomp:

PTe - o regulowanej prędkości obrotowej

PT - stałobrotowe

POMPY LINIOWE

CHARAKTERYSTYKA

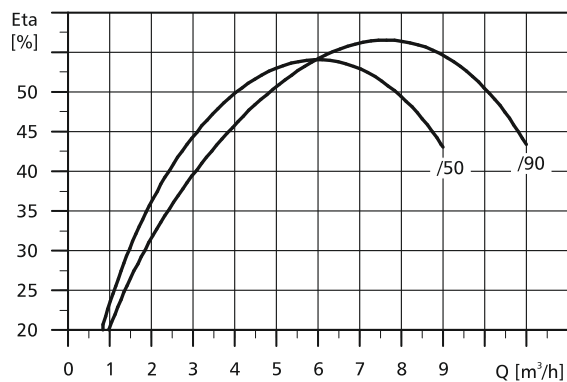
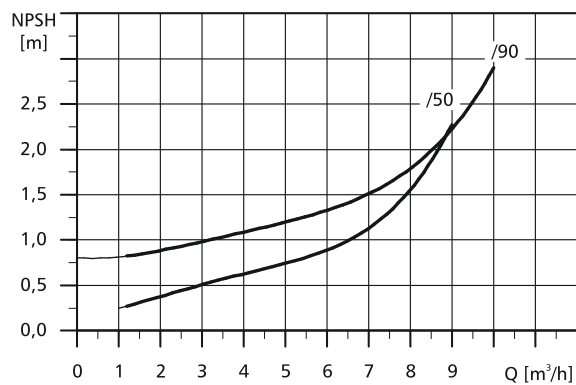
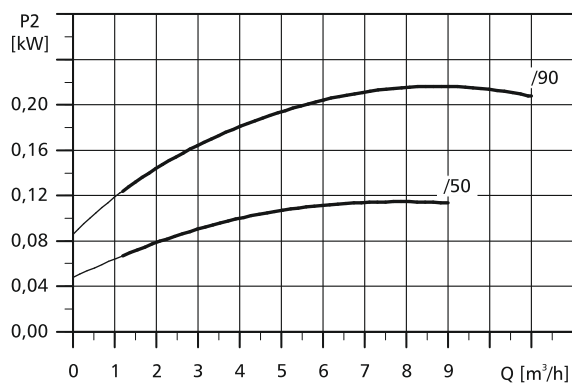
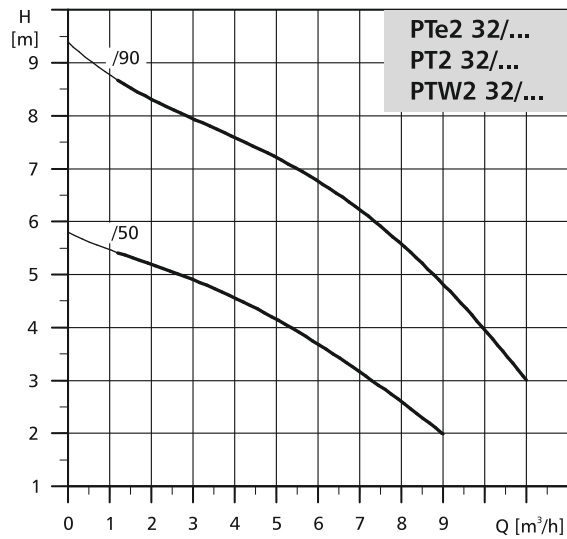

DANE MONTAŻOWE

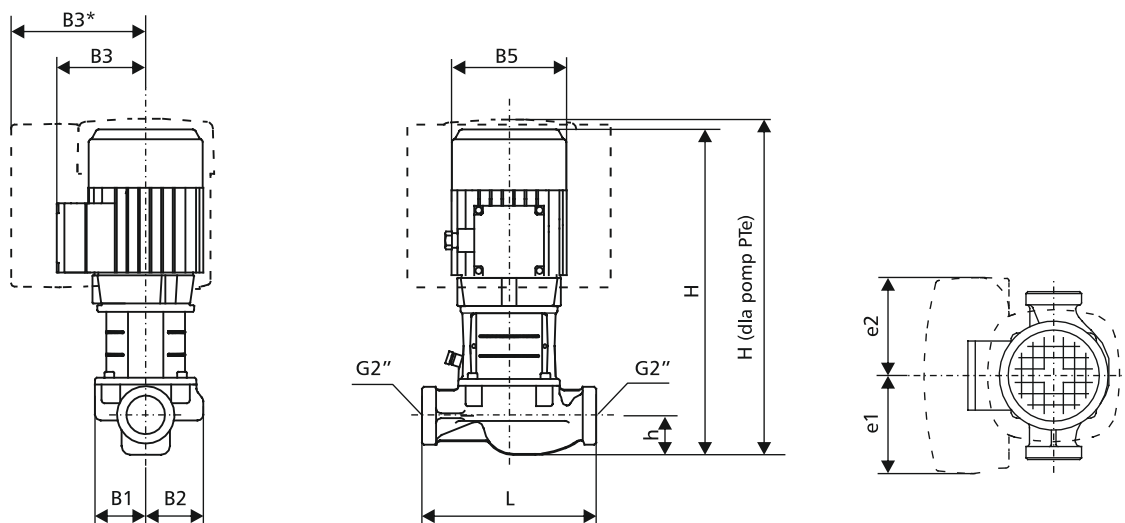

B3* - dotyczy pomp PTe

TYP POMPY	Moc silnika	Wymiary [mm]													Masa [kg]	
		L	H	h	B1	B2	B3	B4	B5	e1	e2	m1	m2	M	PT...	PTW...
PTe2 32/50 M	0,12	180	334	40	51	60	140	-	141	105	105	-	-	-	11	-
PTe2 32/90	0,25	180	334	40	51	60	140	-	141	105	105	-	-	-	12	-
PT2 32/50 M	0,12	180	338	40	51	60	101	-	118	-	-	-	-	-	8	9
PT2 32/50	0,12	180	338	40	51	60	101	-	118	-	-	-	-	-	8	9
PT2 32/90 M	0,25	180	368	40	51	60	111	-	139	-	-	-	-	-	8	9
PT2 32/90	0,25	180	338	40	51	60	101	-	118	-	-	-	-	-	8	9

DANE ELEKTRYCZNE

Moc silnika [kW]	Silniki pomp PTe...			Silniki pomp PT...						
	U [V]	n [min ⁻¹]	In [A]	U [V]	n [min ⁻¹]	η [%]	cos φ	In [A]	In/Ir [A]	
0,12	1x200-240	2900	2,2-1,9	1x230-240	2900	65	0,99	1,05	3,2-3,6	
0,12	-	-	-	3x230-240/400-415	2900	71	0,8-0,72	0,59-0,34	4,2-4,6	
0,25	1x200-240	2900	3,0-2,5	1x230-240	2900	58	0,99	2,05/2	-	
0,25	-	-	-	3x230-240/400-415	2900	73	0,81-0,72	1,18/0,68	4,0-4,4	

Silniki pomp:

PTe - o regulowanej prędkości obrotowej

PT - stałobrotowe

POMPY LINIOWE

CHARAKTERYSTYKA

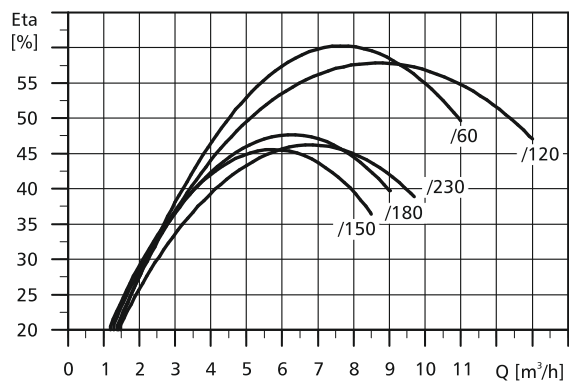
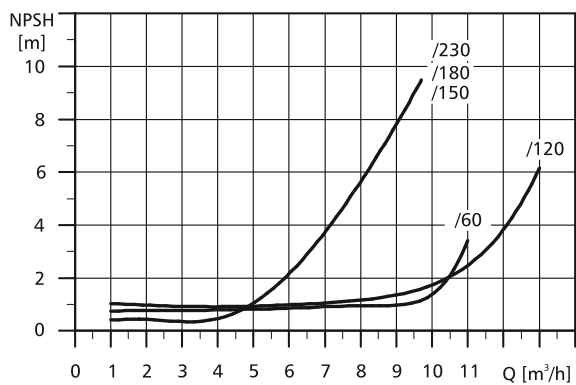
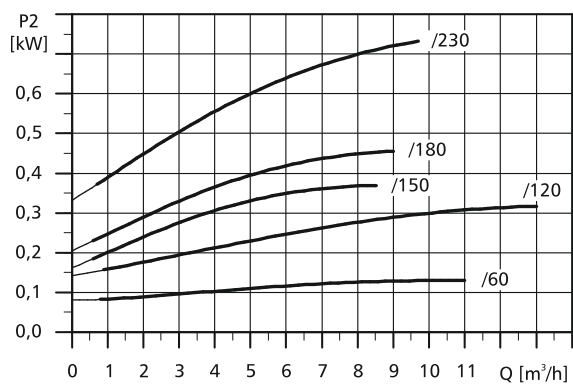
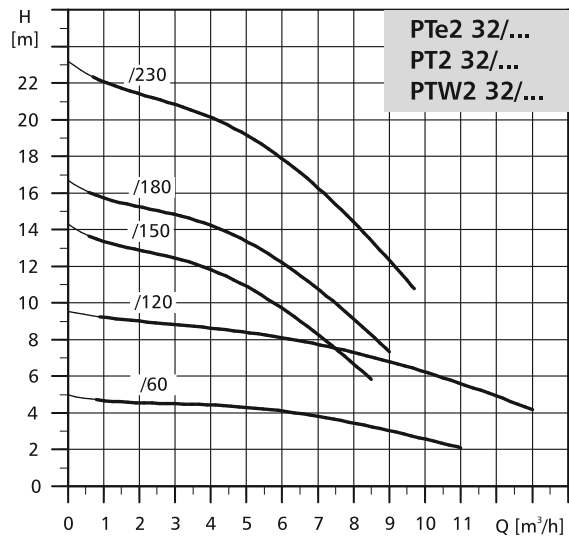

DANE MONTAŻOWE

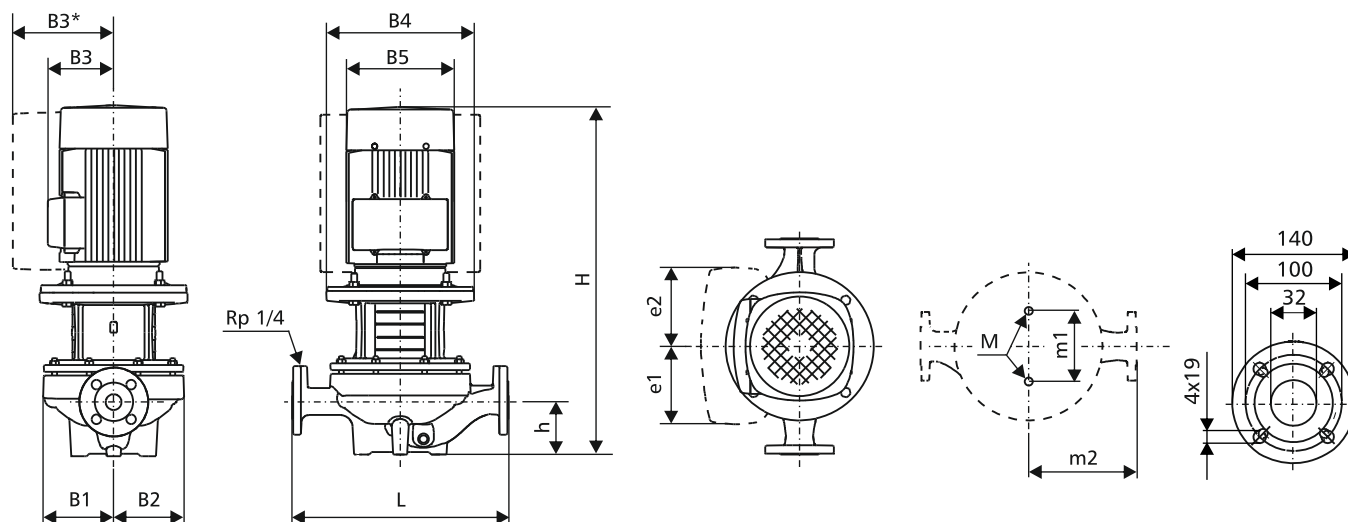

B3* - dotyczy pomp PTe

TYP POMPY	Moc silnika	Wymiary [mm]													Masa [kg]	
		L	H	h	B1	B2	B3	B4	B5	e1	e2	m1	m2	M	PT...	PTW...
PTe2 32/60 M	0,25	220	407	68	75	75	140	90	141	105	105	80	110	M12	22	-
PTe2 32/120 M	0,37	220	385	68	75	75	140	-	141	105	105	80	110	M12	21	-
PTe2 32/150 M	0,37	280	395	79	102	102	140	-	141	105	105	80	140	M12	29	-
PTe2 32/180 M	0,55	280	395	79	102	102	140	-	141	105	105	80	140	M12	29	-
PTe2 32/230 M	0,75	280	447	79	102	102	140	-	141	105	105	80	140	M12	41	-
PTe2 32/230	0,75	280	497	79	102	102	101	-	141	105	105	80	140	M12	41	-
PT2 32/60 M	0,25	220	387	68	75	75	101	90	124	-	-	80	110	M12	16	18
PT2 32/60	0,18	220	386	68	75	75	101	90	124	-	-	80	110	M12	16	18
PT2 32/120 M	0,25	220	385	68	75	75	133	-	141	-	-	80	110	M12	19	21
PT2 32/120	0,37	220	385	68	75	75	133	-	141	-	-	80	110	M12	19	21
PT2 32/150 M	0,37	280	395	79	102	102	133	-	141	-	-	80	140	M12	23	26
PT2 32/150	0,37	280	395	79	102	102	109	-	141	-	-	80	140	M12	23	26
PT2 32/180 M	0,55	280	447	79	102	102	133	-	141	-	-	80	140	M12	24	27
PT2 32/180	0,55	280	395	79	102	102	109	-	141	-	-	80	140	M12	24	27
PT2 32/230 M	0,75	280	447	79	102	102	133	-	141	-	-	80	140	M12	25	28
PT2 32/230	0,75	280	447	79	102	102	109	-	141	-	-	80	140	M12	25	28

DANE ELEKTRYCZNE

Moc silnika [kW]	Silniki pomp PTe...			Silniki pomp PT...					
	U [V]	n [min ⁻¹]	In [A]	U [V]	n [min ⁻¹]	η [%]	cos φ	In [A]	In/Ir [A]
0,18	-	-	-	3x230-240/400-415	2900	73	0,81-0,72	1,18/0,68	4,0-4,4
0,25	1x200-240	2900	3,0-2,5	1x230-240	2900	58	0,99	2,05/2	-
0,37	1x200-240	2900	3,1-2,6	1x230-240	2900	60	0,99	2,95/2,7	2,8
0,37	-	-	-	3x230-240/400-415	2900	78,5	0,8-0,7	1,74/1	4,9-5,3
0,55	1x200-240	2900	3,9-3,6	1x230-240	2900	66	0,99	4/3,65	2,8
0,55	-	-	-	3x230-240/400-415	2900	80	0,8-0,7	2,5/1,44	1,9
0,75	1x200-240	2900	5,1-4,7	1x230-240	2900	96	0,99	5,1/4,75	3,0
0,75	3x380-480	2900	2,0-1,8	3x230-240/400-415	2900	80,7	0,81-0,71	3,3/1,9	5,8-6,2

Silniki pomp:

PTe - o regulowanej prędkości obrotowej

PT - stałobrotowe

POMPY LINIOWE

CHARAKTERYSTYKA

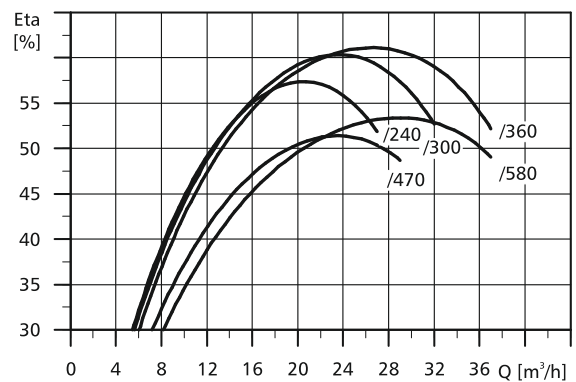
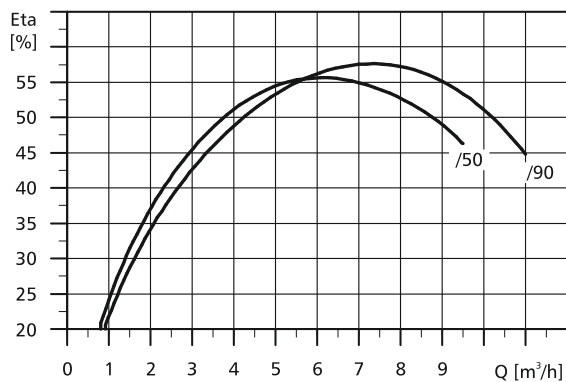
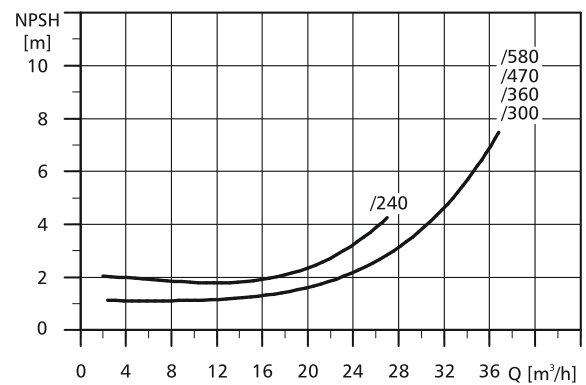
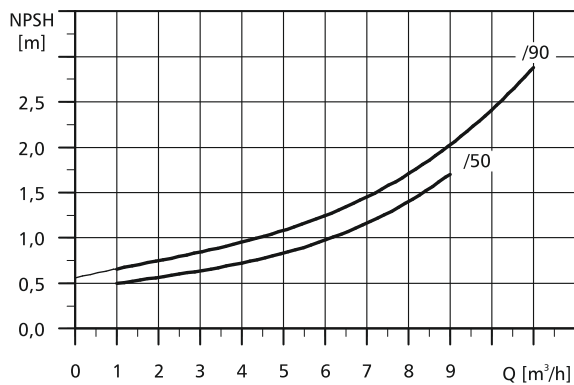
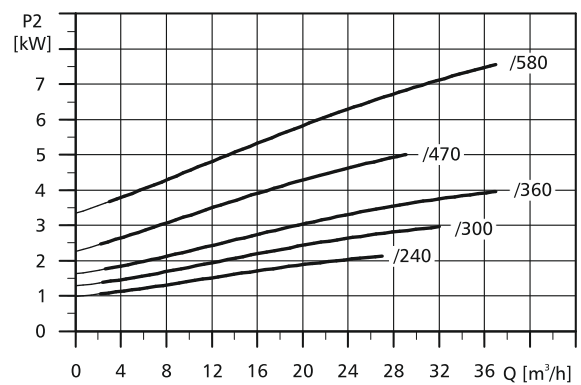
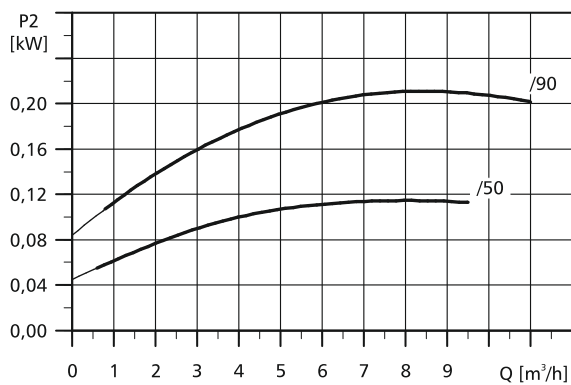
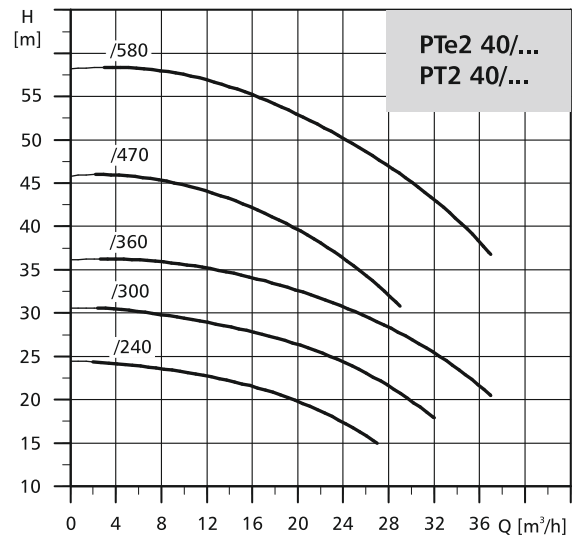
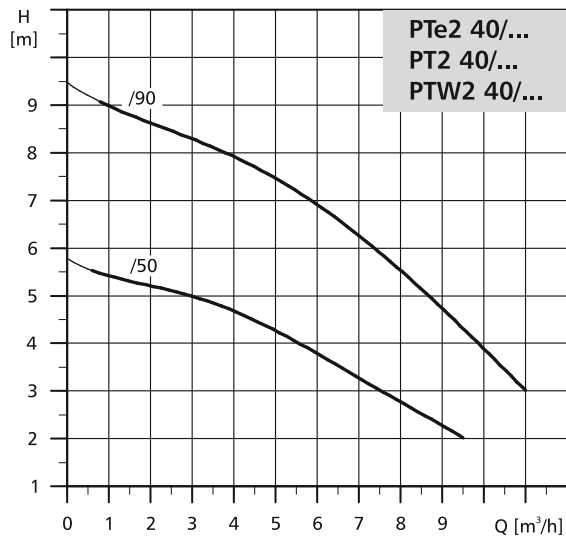

DANE MONTAŻOWE

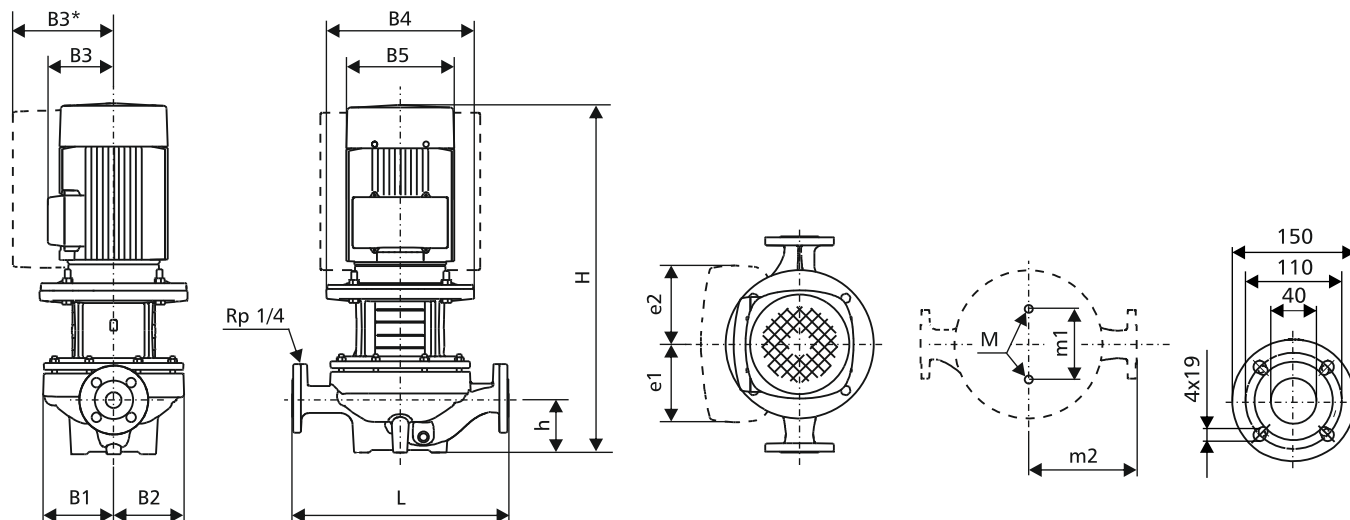

B3* - dotyczy pomp PTe

TYP POMPY	Moc silnika	Wymiary [mm]													Masa [kg]	
		L	H	h	B1	B2	B3	B4	B5	e1	e2	m1	m2	M	PT...	PTW...
PTe2 40/50 M	0.37	250	364	55	75	75	140	-	141	105	105	-	-	-	17	-
PTe2 40/90 M	0.25	250	364	55	75	75	141	-	141	105	105	-	-	-	17	-
PTe2 40/240	2.2	340	587	100	130	117	167	200	178	132	132	144	170	M16	58	-
PTe2 40/300	3.0	340	629	100	130	117	177	250	198	132	132	144	170	M16	66	-
PTe2 40/360	4.0	340	666	100	130	117	188	250	220	145	145	144	170	M16	73	-
PTe2 40/470	5.5	440	726	110	149	144	188	300	220	145	145	144	220	M16	95	-
PTe2 40/580	7.5	440	714	110	149	144	213	300	260	145	145	144	220	M16	106	-
PT2 40/50 M	0.12	250	353	55	75	75	101	-	118	-	-	-	-	-	12	13
PT2 40/50	0.12	250	353	55	75	75	101	-	118	-	-	-	-	-	12	13
PT2 40/90 M	0.25	250	383	55	75	75	111	-	139	-	-	-	-	-	12	13
PT2 40/90	0.25	250	353	55	75	75	101	-	118	-	-	-	-	-	12	13
PT2 40/240	2.2	340	587	100	130	117	110	200	178	-	-	144	170	M16	53	-
PT2 40/300	3.0	340	629	100	130	117	120	250	198	-	-	144	170	M16	65	-
PT2 40/360	4.0	340	666	100	130	117	134	250	220	-	-	144	170	M16	70	-
PT2 40/470	5.5	440	726	110	149	144	134	300	220	-	-	144	220	M16	90	-
PT2 40/580	7.5	440	714	110	149	144	159	300	260	-	-	144	220	M16	104	-

DANE ELEKTRYCZNE

Moc silnika [kW]	Silniki pomp PTe...			Silniki pomp PT...					
	U [V]	n [min ⁻¹]	In [A]	U [V]	n [min ⁻¹]	η [%]	cos φ	In [A]	In/Ir [A]
0,12	-	-	-	1x230-240	2900	65	0,99	1,05	3,2-3,6
0,12	-	-	-	3x230-240/400-415	2900	71	0,8-0,72	0,59/0,34	4,2-4,6
0,25	-	-	-	1x230-240	2900	58	0,99	2,05/2	-
0,25	-	-	-	3x230-240/400-415	2900	73	0,81-0,72	1,18/0,68	4,0-4,4
0,37	1x220-240	2900	3,1-2,6	-	-	-	-	-	-
2,2	3x380-480	2900	4,6-3,8	3x230-240/400-415	2900	85,9	0,89-0,87	7,70/4,45	8,5-9,3
3,0	3x380-480	2900	6,2-5,0	3x230-240/400-415	2900	87,1	0,87-0,82	11,0/6,3	8,4-9,2
4,0	3x380-480	2900	8,1-6,6	3x230-240/400-415	2900	88,1	0,87	13,6/7,9	10-11,1
5,5	3x380-480	2900	11,0-8,8	3x230-240/400-415	2900	89,2	0,87-0,82	11,0	10,8-11,8
7,5	3x380-480	2900	14,8-11,6	3x230-240/400-415	2900	90,4	0,88-0,82	14,4-14,0/8,3-8,1	7,8-9,1

Silniki pomp:

PTe - o regulowanej prędkości obrotowej

PT - stałobrotowe

POMPY LINIOWE

CHARAKTERYSTYKA

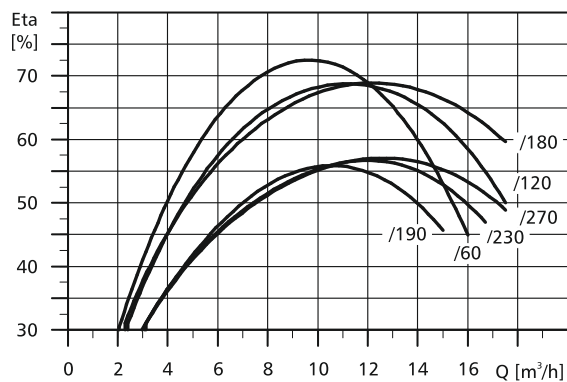
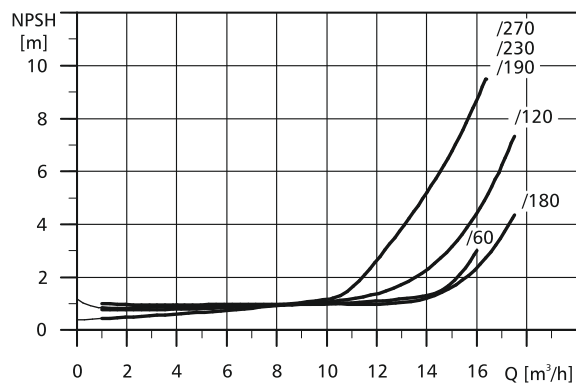
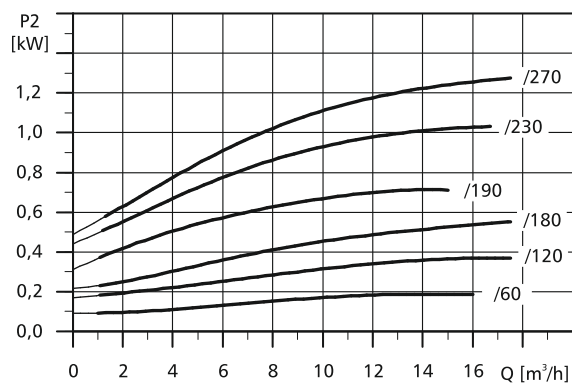
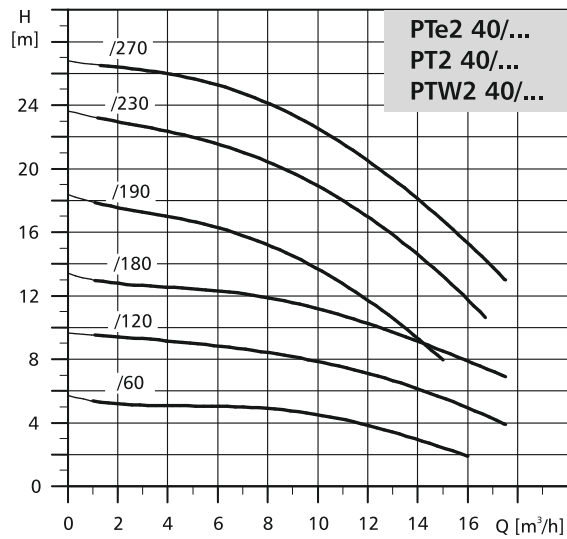

DANE MONTAŻOWE

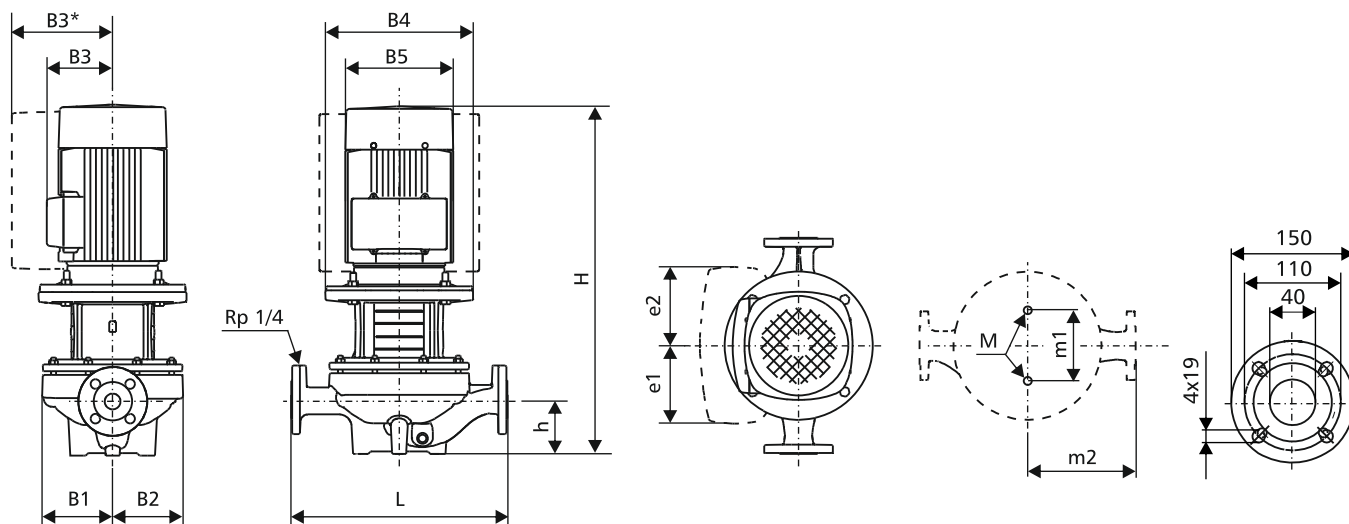

B3* - dotyczy pomp PTe

TYP POMPY	Moc silnika	Wymiary [mm]													Masa [kg]	
		L	H	h	B1	B2	B3	B4	B5	e1	e2	m1	m2	M	PT...	PTW...
PTe2 40/60 M	0,37	250	395	67	75	75	140	-	141	105	105	80	125	M12	23	-
PTe2 40/120 M	0,37	250	388	67	75	75	140	-	141	105	105	80	125	M12	22	-
PTe2 40/180 M	0,55	250	390	68	100	100	141	-	141	105	105	80	125	M12	29	-
PTe2 40/190 M	0,75	320	320	68	102	102	140	-	141	105	105	120	160	M12	44	-
PTe2 40/190	0,75	320	490	68	102	102	167	-	178	132	132	120	160	M12	44	-
PTe2 40/230 M	1,1	320	439	68	102	102	140	-	141	105	105	120	160	M12	46	-
PTe2 40/230	1,1	320	490	68	102	102	167	-	178	132	132	120	160	M12	46	-
PTe2 40/270	1,5	320	500	68	102	102	167	-	178	132	132	120	160	M12	37	-
PT2 40/60 M	0,25	250	387	67	75	75	133	-	141	-	-	80	125	M12	20	22
PT2 40/60	0,25	250	366	67	75	75	109	-	141	-	-	80	125	M12	20	22
PT2 40/120 M	0,37	250	387	67	75	75	133	-	141	-	-	80	125	M12	20	22
PT2 40/120	0,37	250	387	67	75	75	109	-	141	-	-	80	125	M12	20	22
PT2 40/180 M	0,55	250	442	68	100	100	133	-	141	-	-	80	125	M12	24	26
PT2 40/180	0,55	250	390	68	100	100	109	-	141	-	-	80	125	M12	24	26
PT2 40/190M	0,75	320	439	68	102	102	133	-	141	-	-	120	160	M12	29	32
PT2 40/190	0,75	320	439	68	102	102	109	-	141	-	-	120	160	M12	29	32
PT2 40/230 M	1,1	320	499	68	102	102	139	-	178	-	-	120	160	M12	36	41
PT2 40/230	1,1	320	510	68	102	102	109	-	141	-	-	120	160	M12	36	41
PT2 40/270 M	1,5	320	539	68	102	102	139	-	178	-	-	120	160	M12	39	43
PT2 40/270	1,5	320	500	68	102	102	110	-	178	-	-	120	160	M12	39	43

DANE ELEKTRYCZNE

Moc silnika [kW]	Silniki pomp PTe...			Silniki pomp PT...					
	U [V]	n [min ⁻¹]	In [A]	U [V]	n [min ⁻¹]	η [%]	cos φ	In [A]	In/Ir [A]
0,25	-	-	-	1x230-240	2900	58	0,99	2,05/2	-
0,25	-	-	-	3x230-240/400-415	2900	73	0,81-0,72	1,18/0,68	4,0-4,4
0,37	1x200-240	2900	3,1-2,6	1x230-240	2900	60	0,99	2,95/2,7	2,8
0,37	-	-	-	3x230-240/400-415	2900	78,5	0,8-0,7	1,74/1	4,9-5,3
0,55	1x200-240	2900	3,9-3,6	1x230-240	2900	66	0,99	4/3,65	2,8
0,55	-	-	-	3x230-240/400-415	2900	80	0,8-0,7	2,5/1,44	1,9
0,75	1x200-240	2900	5,1-4,7	1x230-240	2900	69	0,99	5,1/4,75	3,00
0,75	3x380-480	2900	2,0-1,8	3x230-240/400-415	2900	80,7	0,81-0,71	3,3/1,9	5,8-6,2
1,1	1x200-240	2900	7,1-6,6	1x230-240	2900	-	0,98-0,99	7,4/6,7	3,9/3,9
1,1	3x380-480	2900	2,6-2,3	3x230-240/400-415	2900	80,7	0,83-0,76	4,35-2,5	4,5-5,0
1,5	-	-	-	1x230-240	2900	72-74	0,98-0,99	9,9/8,	3,9/3,9
1,5	3x380-480	2900	3,3-2,7	3x230-240/400-415	2900	84,2	0,97-0,82	5,45/3,15	8,5-9,3

Silniki pomp:

PTe - o regulowanej prędkości obrotowej

PT - stałobrotowe

POMPY LINIOWE

CHARAKTERYSTYKA

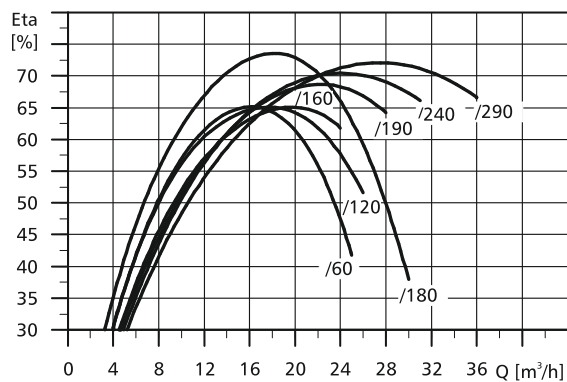
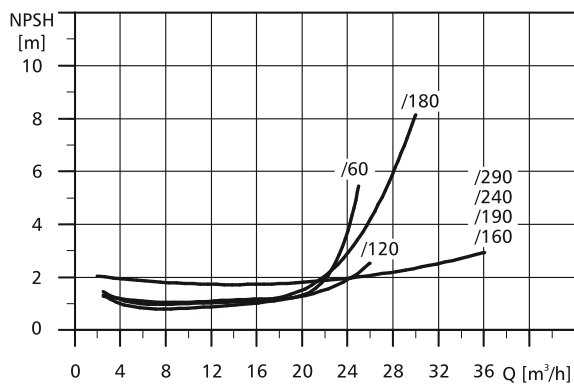
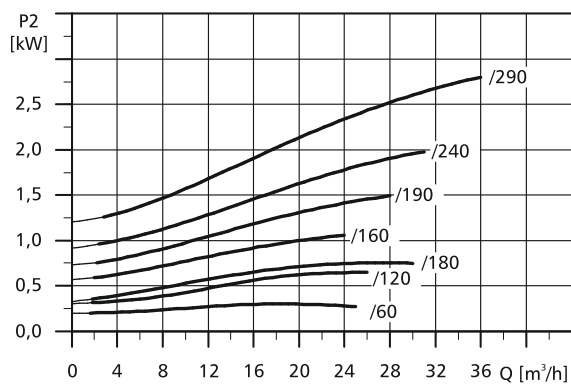
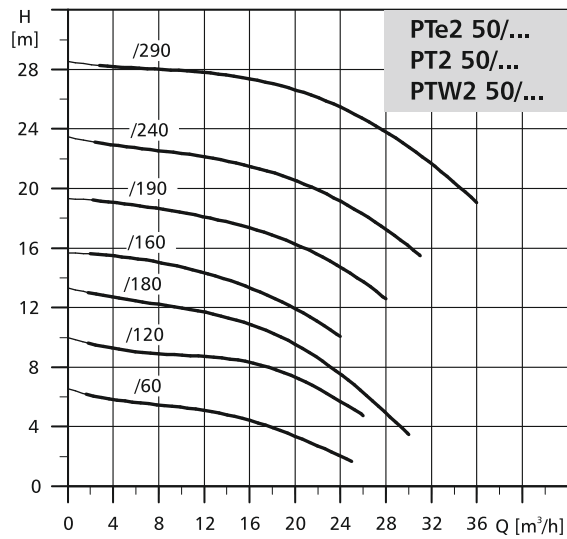

DANE MONTAŻOWE

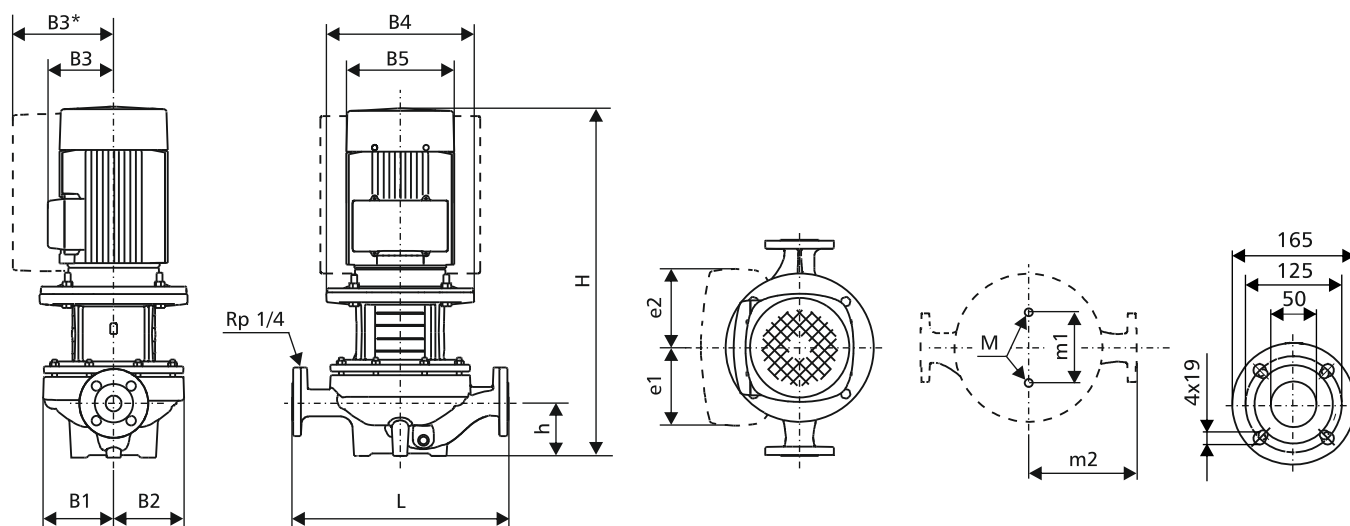

B3* - dotyczy pomp PTe

TYP POMPY	Moc silnika	Wymiary [mm]													Masa [kg]	
		L	H	h	B1	B2	B3	B4	B5	e1	e2	m1	m2	M	PT...	PTW...
PTe2 50/60 M	0,37	280	403	75	90	75	140	105	141	105	105	120	140	M12	24	-
PTe2 50/120 M	0,75	280	442	75	100	100	140	120	141	105	105	120	140	M12	40	-
PTe2 50/120	0,75	280	491	75	100	100	140	120	178	132	105	120	140	M12	40	-
PTe2 50/160 M	1,1	340	498	115	117	117	140	200	178	105	105	144	170	M16	53	-
PTe2 50/160	1,1	340	548	115	117	117	140	200	141	132	105	144	170	M16	53	-
PTe2 50/180 M	0,75	280	441	75	100	100	140	200	141	105	105	120	140	M12	41	-
PTe2 50/180	0,75	280	491	75	100	100	140	200	178	132	105	120	140	M12	41	-
PTe2 50/190	1,5	340	548	115	117	117	167	200	178	132	132	144	170	M16	54	-
PTe2 50/240	2,2	340	588	115	117	117	167	200	178	132	132	144	170	M16	59	-
PTe2 50/290	3,0	340	630	115	117	117	177	250	198	132	132	144	170	M16	67	-
PT2 50/60 M	0,37	280	403	75	90	75	133	105	141	-	-	120	140	M12	20	22
PT2 50/60	0,37	280	403	75	90	75	133	105	141	-	-	120	140	M12	20	22
PT2 50/120 M	0,75	280	441	75	100	100	133	120	141	-	-	120	140	M12	28	31
PT2 50/120	0,75	280	441	75	100	100	133	120	141	-	-	120	140	M12	28	31
PT2 50/160 M	1,1	340	518	115	117	117	109	200	141	-	-	144	170	M16	47	-
PT2 50/160	1,1	340	518	115	117	117	109	200	141	-	-	144	170	M16	47	-
PT2 50/180 M	0,75	280	441	75	100	100	133	200	141	-	-	120	140	M12	28	32
PT2 50/180	0,75	280	441	75	100	75	109	200	141	-	-	120	140	M12	28	32
PT2 50/190 M	1,5	340	548	115	117	117	110	200	141	-	-	144	170	M16	48	-
PT2 50/190	1,5	340	548	115	117	117	110	200	178	-	-	144	170	M16	48	-
PT2 50/240	2,2	340	588	115	117	117	110	200	178	-	-	144	170	M16	54	-
PT2 50/290	3,0	340	630	115	117	117	120	250	198	-	-	144	170	M16	65	-

DANE ELEKTRYCZNE

Moc silnika [kW]	Silniki pomp PTe...			Silniki pomp PT...					
	U [V]	n [min ⁻¹]	In [A]	U [V]	n [min ⁻¹]	η [%]	cos φ	In [A]	In/Ir [A]
0,37	1x200-240	2900	3,1-2,6	1x230-240	2900	60	0,99	2,95/2,7	2,8
0,37	-	-	-	3x230-240/400-415	2900	78,5	0,8-0,7	1,74/1	4,9-5,3
0,75	1x200-240	2900	5,1-4,7	1x230-240	2900	69	0,99	5,1/4,75	3,0
0,75	3x380-480	2900	2,0-1,8	3x230-240/400-415	2900	80,7	0,81-0,71	3,3/1,9	5,8-6,2
1,1	1x200-240	2900	7,1-6,6	1x230-240	2900	-	0,98-0,99	7,4/6,7	3,9/3,9
1,1	3x380-480	2900	2,6-2,3	3x230-240/400-415	2900	80,7	0,83-0,76	4,35-2,5	4,5-5,0
1,5	-	-	-	1x230-240	2900	72-74	0,98-0,00	9,9/8,9	3,9/3,9
1,5	3x380-480	2900	3,3-2,7	3x230-240/400-415	2900	84,2	0,87-0,82	5,45/3,15	8,5-9,3
2,2	3x380-480	2900	4,6-3,8	3x230-240/400-415	2900	85,9	0,89-0,87	7,70/4,45	8,5-9,3
3,0	3x380-480	2900	6,2-5,0	3x230-240/400-415	2900	87,1	0,87-0,82	11,0/6,3	8,4-9,2

Silniki pomp:

PTe - o regulowanej prędkości obrotowej

PT - stałobrotowe

POMPY LINIOWE

CHARAKTERYSTYKA

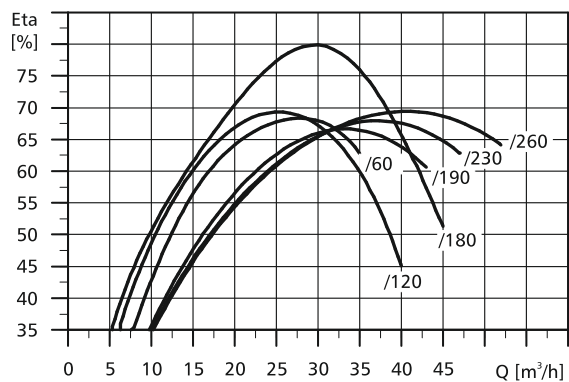
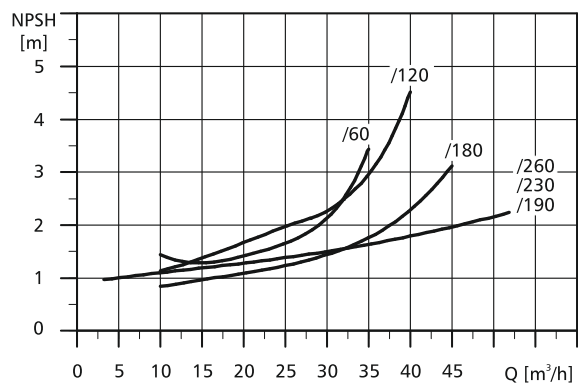
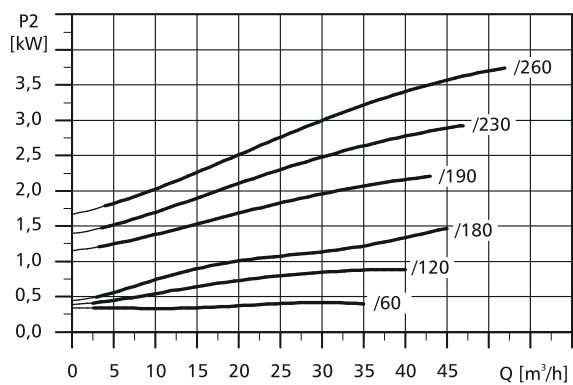
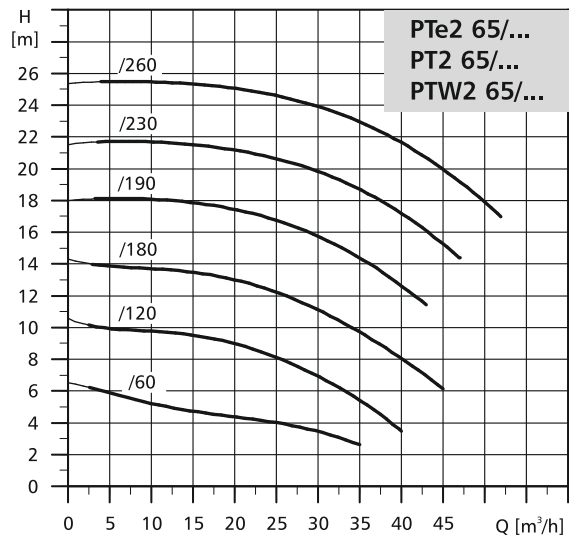

DANE MONTAŻOWE

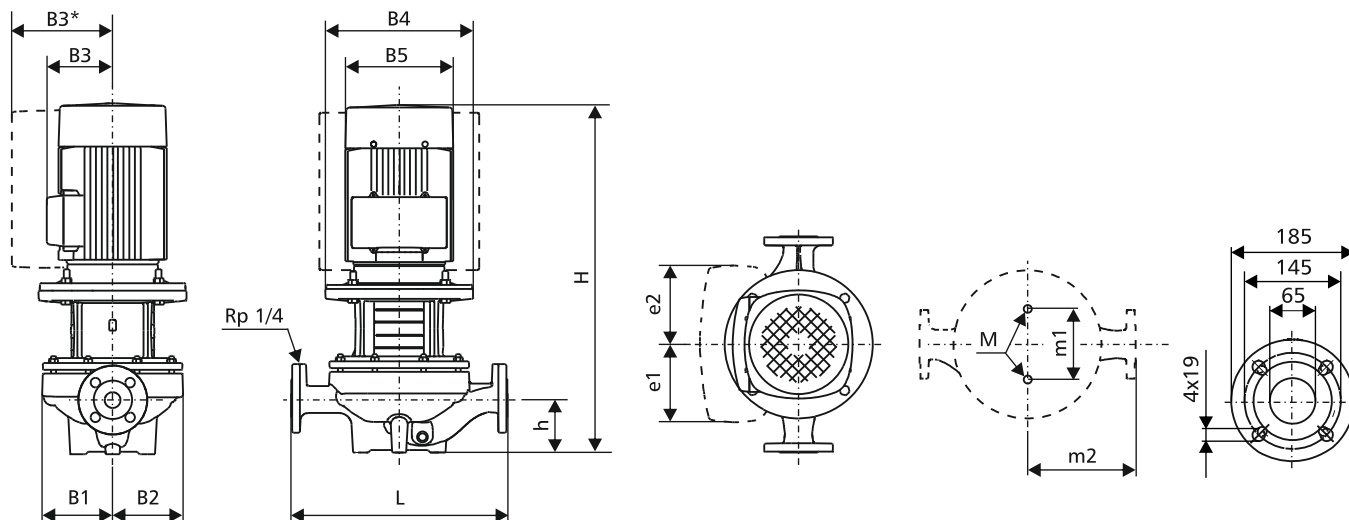

B3* - dotyczy pomp PTe

TYP POMPY	Moc silnika	Wymiary [mm]													Masa [kg]	
		L	H	h	B1	B2	B3	B4	B5	e1	e2	m1	m2	M	PT...	PTW...
PTe2 65/60 M	0,55	340	418	82	93	93	140	-	141	105	105	120	170	M12	30	-
PTe2 65/120 M	1,1	340	462	82	100	100	140	-	141	105	105	120	170	M12	40	-
PTe2 65/120	1,1	340	512	82	100	100	167	-	178	132	132	120	170	M12	40	-
PTe2 65/180	1,5	340	517	82	100	100	167	-	178	132	132	120	170	M12	45	-
PTe2 65/190	2,2	360	598	105	142	124	167	200	178	132	132	144	180	M16	63	-
PTe2 65/230	3,0	360	641	105	142	124	177	250	198	132	132	144	180	M16	71	-
PTe2 65/260	4,0	360	678	105	142	124	188	250	220	145	145	144	180	M16	77	-
PT2 65/60 M	0,55	340	468	82	93	93	133	-	141	-	-	120	170	M12	26	30
PT2 65/60	0,55	340	418	82	93	93	109	-	141	-	-	120	170	M12	26	30
PT2 65/120 M	1,1	340	517	82	100	100	139	-	178	-	-	120	170	M12	31	35
PT2 65/120	1,1	340	532	82	100	100	109	-	141	-	-	120	170	M12	31	35
PT2 65/180 M	1,5	340	557	82	100	100	139	-	178	-	-	120	170	M12	38	42
PT2 65/180	1,5	340	507	82	100	100	110	-	178	-	-	120	170	M12	38	42
PT2 65/190	2,2	360	598	105	142	124	110	200	178	-	-	144	180	M16	57	-
PT2 65/230	3,0	360	641	105	142	124	120	250	198	-	-	144	180	M16	69	-
PT2 65/260	4,0	360	678	105	142	124	134	250	220	-	-	144	180	M16	74	-

DANE ELEKTRYCZNE

Moc silnika [kW]	Silniki pomp PTe...			Silniki pomp PT...					
	U [V]	n [min ⁻¹]	In [A]	U [V]	n [min ⁻¹]	η [%]	cos φ	In [A]	In/Ir [A]
0,55	1x200-240	2900	3,9-3,6	1x230-240	2900	66	0,99	4/3,65	2,8
0,55	-	-	-	3x230-240/400-415	2900	80	0,8-0,7	2,5/1,44	1,9
1,1	1x200-240	2900	7,1-6,6	1x230-240	2900	-	0,98-0,99	7,4/6,7	3,9/3,9
1,1	3x380-480	2900	2,6-2,3	3x230-240/400-415	2900	80,7	0,83-0,76	4,35-2,5	4,5-5,0
1,5	-	-	-	1x230-240	2900	72-74	0,98-0,99	9,9/8,9	3,9/3,9
1,5	3x380-480	2900	3,3-2,7	3x230-240/400-415	2900	84,2	0,87-0,82	5,45/3,15	8,5-9,3
2,2	3x380-480	2900	4,6-3,8	3x230-240/400-415	2900	85,9	0,89-0,87	7,70/4,45	8,5-9,3
3,0	3x380-480	2900	6,2-5,0	3x230-240/400-415	2900	87,1	0,87-0,82	11,0/6,3	8,4-9,2
4,0	3x380-480	2900	8,1-6,6	3x230-240/400-415	2900	88,1	0,87	13,6/7,9	10-11,1

Silniki pomp:

PTe - o regulowanej prędkości obrotowej

PT - stałobrotowe

POMPY LINIOWE

CHARAKTERYSTYKA

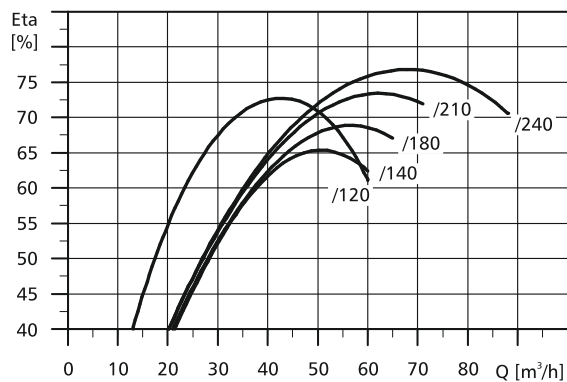
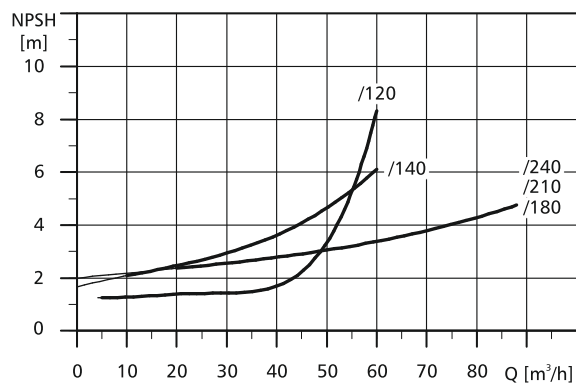
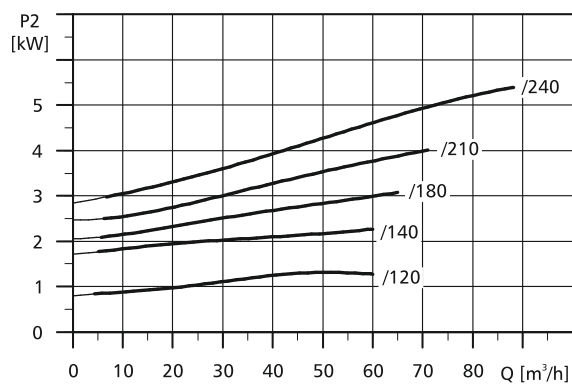
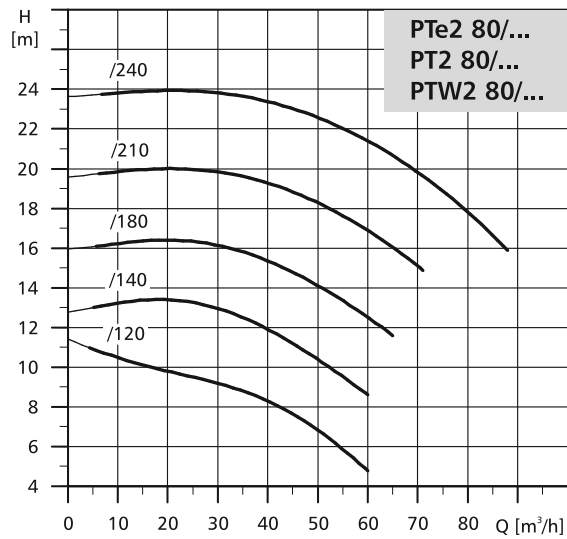

DANE MONTAŻOWE

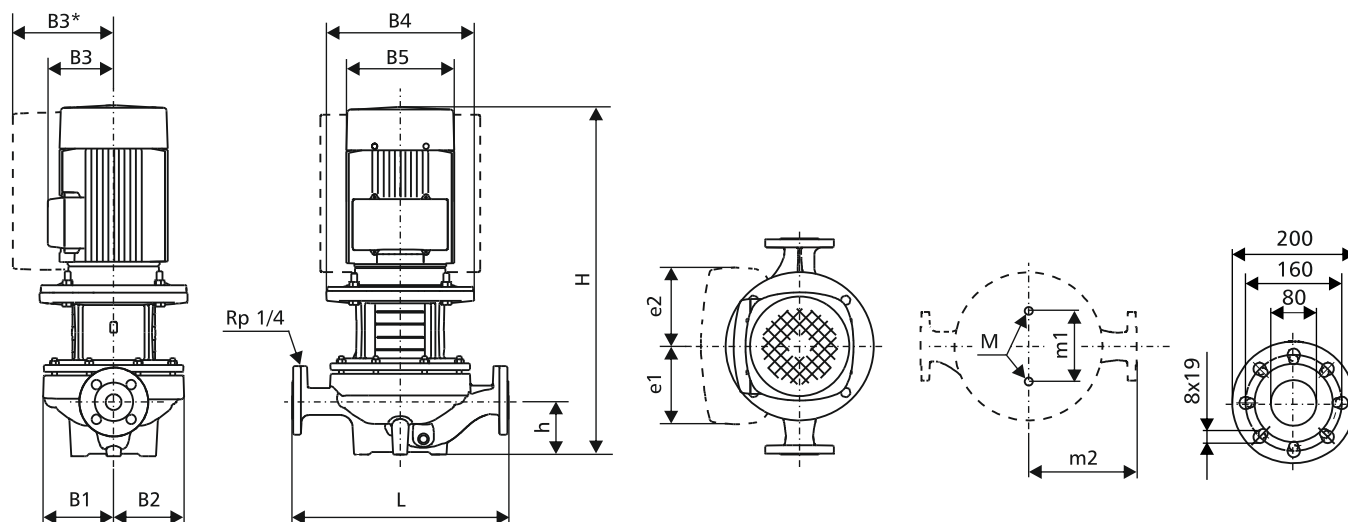

B3* - dotyczy pomp PTe

TYP POMPY	Moc silnika	Wymiary [mm]													Masa [kg]	
		L	H	h	B1	B2	B3	B4	B5	e1	e2	m1	m2	M	PT...	PTW...
PTe2 80/120 PN6	1,5	360	541	97	120	100	167	135	178	132	132	160	180	M16	52	-
PTe2 80/120 PN10	1,5	360	541	97	120	100	167	135	178	132	132	144	180	M16	52	-
PTe2 80/140	2,2	360	602	105	125	119	167	200	178	132	132	144	180	M16	66	-
PTe2 80/180	3,0	360	644	105	125	119	177	250	198	132	132	144	180	M16	74	-
PTe2 80/210	4,0	360	681	105	125	119	188	250	220	145	145	144	180	M16	80	-
PTe2 80/240	5,5	360	739	105	125	119	188	300	220	145	145	144	180	M16	97	-
PT2 80/120 M PN6	1,5	360	581	97	120	100	139	135	178	-	-	144	180	M16	43	47
PT2 80/120 M PN10	1,5	360	581	97	120	100	139	135	178	-	-	144	180	M16	43	47
PT2 80/120 PN6	1,5	360	581	97	120	119	139	135	178	-	-	144	180	M16	43	47
PT2 80/120 PN10	1,5	360	581	97	120	119	139	135	178	-	-	144	180	M16	43	47
PT2 80/140	2,2	360	602	105	125	119	110	200	178	-	-	144	180	M16	61	-
PT2 80/180	3,0	360	644	105	125	119	120	250	198	-	-	144	180	M16	65	-
PT2 80/210	4,0	360	681	105	125	119	134	250	220	-	-	144	180	M16	78	-
PT2 80/240	5,5	360	739	105	125	119	134	300	220	-	-	144	180	M16	93	-

DANE ELEKTRYCZNE

Moc silnika [kW]	Silniki pomp PTe...			Silniki pomp PT...					
	U [V]	n [min ⁻¹]	In [A]	U [V]	n [min ⁻¹]	η [%]	cos φ	In [A]	In/Ir [A]
1,5	-	-	-	1x230-240	2900	72-74	0,98-0,99	9,9/8,9	3,9/3,9
1,5	3x380-480	2900	3,3-2,7	3x230-240/400-415	2900	84,2	0,87-0,82	5,45/3,15	8,5-9,3
2,2	3x380-480	2900	4,6-3,8	3x230-240/400-415	2900	85,9	0,89-0,87	7,70/4,45	8,5-9,3
3,0	3x380-480	2900	6,2-5,0	3x230-240/400-415	2900	87,1	0,87-0,82	11,0/6,3	8,4-9,2
4,0	3x380-480	2900	8,1-6,6	3x230-240/400-415	2900	88,1	0,87	13,6/7,9	10-11,1
5,5	3x380-480	2900	11,0-8,8	3x230-240/400-415	2900	89,2	0,87-0,82	11,0	10,8-11,8

Silniki pomp:

PTe - o regulowanej prędkości obrotowej

PT - stałobrotowe

POMPY LINIOWE

CHARAKTERYSTYKA

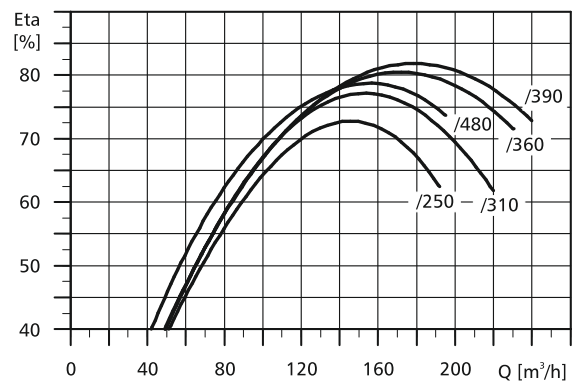
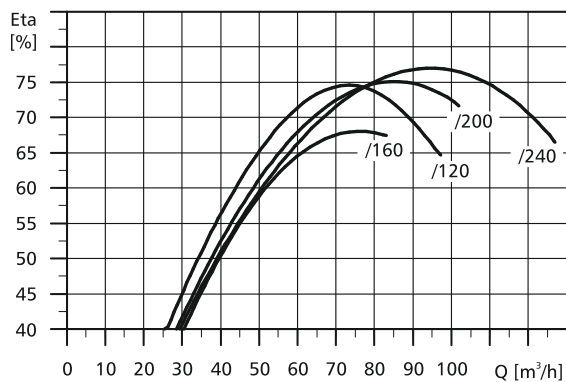
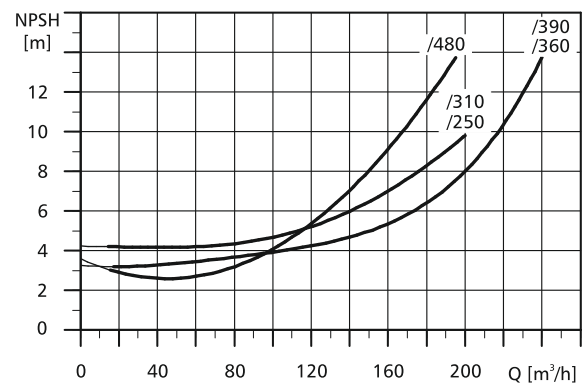
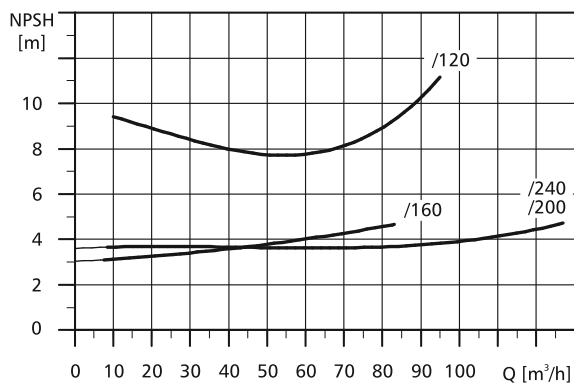
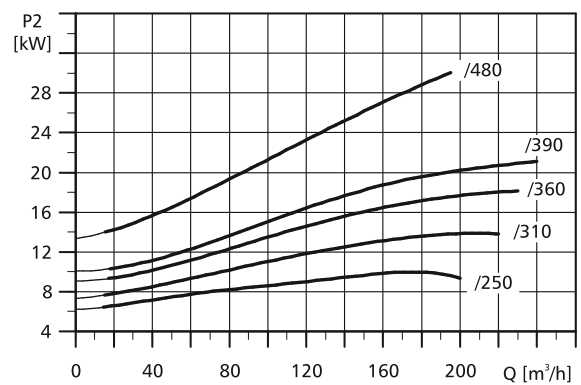
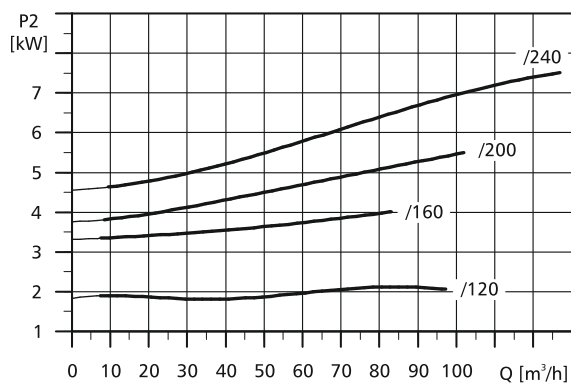
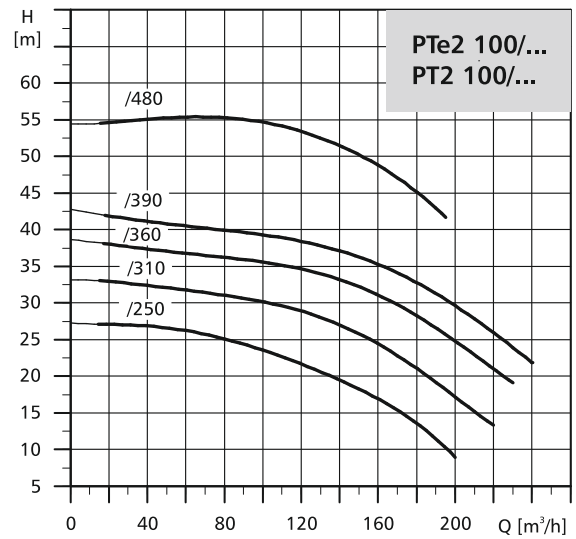
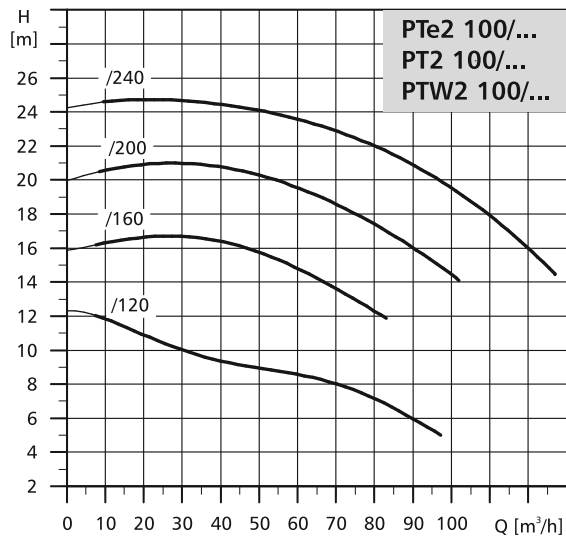

DANE MONTAŻOWE

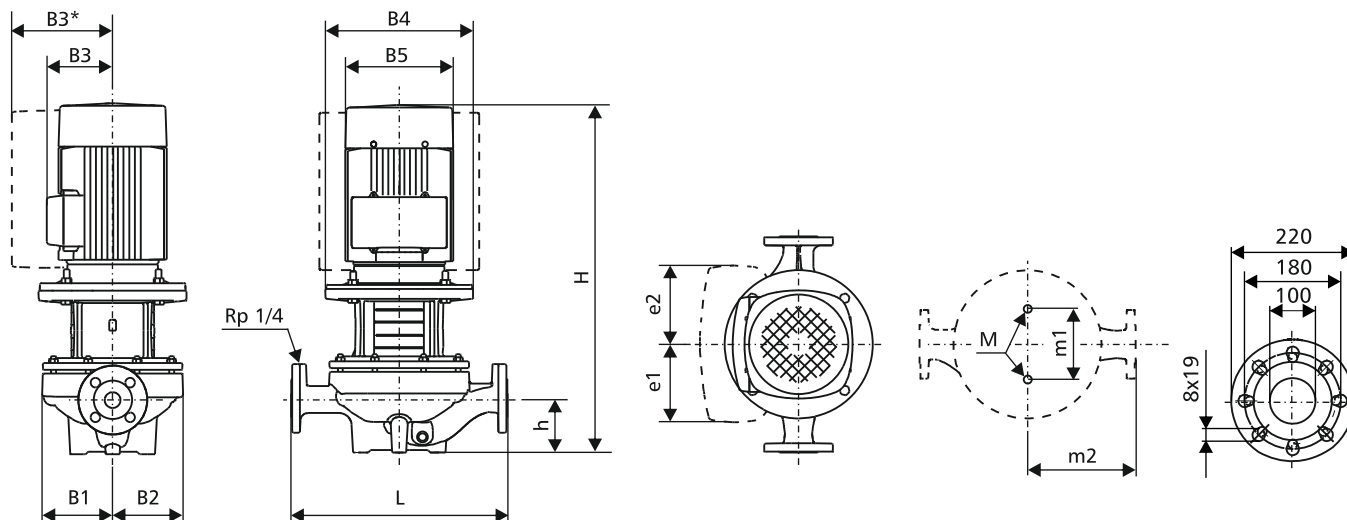

B3* - dotyczy pomp PTe

TYP POMPY	Moc silnika	Wymiary [mm]													Masa [kg]	
		L	H	h	B1	B2	B3	B4	B5	e1	e2	m1	m2	M	PT...	PTW...
PTe2 100/120 PN6	2,2	450	613	107	125	100	167	-	178	132	132	160	225	M16	61	-
PTe2 100/120 PN10	2,2	450	613	107	125	100	167	-	178	132	132	160	225	M16	61	-
PTe2 100/160	4,0	500	718	140	124	156	188	-	220	145	145	144	250	M16	95	-
PTe2 100/200	5,5	500	776	140	124	156	188	-	220	145	145	144	250	M16	112	-
PTe2 100/240	7,5	500	764	140	124	156	188	-	260	145	145	144	250	M16	127	-
PTe2 100/250	11,0	550	881	140	190	151	308	-	314	210	210	230	275	M16	206	-
PTe2 100/310	15,0	550	881	140	151	190	417	-	314	148	148	230	275	M16	209	-
PTe2 100/360	18,5	550	925	140	151	190	417	-	314	148	148	230	275	M16	234	-
PTe2 100/390	22,0	550	951	140	190	151	308	-	314	210	210	230	275	M16	247	-
PT2 100/120 PN6	2,2	450	613	107	100	125	110	-	178	-	-	160	225	M16	53	58
PT2 100/120 PN10	2,2	450	613	107	100	125	110	-	178	-	-	160	225	M16	53	58
PT2 100/160	4,0	500	718	140	156	124	134	250	220	-	-	144	250	M16	93	-
PT2 100/200	5,5	500	776	140	156	124	134	300	220	-	-	144	250	M16	108	-
PT2 100/240	7,5	500	764	140	156	124	134	300	260	-	-	144	250	M16	122	-
PT2 100/250	11,0	550	881	140	190	151	241	350	314	-	-	230	275	M16	175	-
PT2 100/310	15,0	550	881	140	190	151	241	350	314	-	-	230	275	M16	204	-
PT2 100/360	18,0	550	925	140	190	151	241	350	314	-	-	230	275	M16	207	-
PT2 100/390	22,0	550	925	140	190	151	285	350	336	-	-	230	275	M16	221	-
PT2 100/480	30,0	550	1058	140	201	173	341	400	407	-	-	230	275	M16	384	-

DANE ELEKTRYCZNE

Moc silnika [kW]	Silniki pomp PTe...			Silniki pomp PT...					
	U [V]	n [min ⁻¹]	In [A]	U [V]	n [min ⁻¹]	η [%]	cos φ	In [A]	In/Ir [A]
2,2	3x380-480	2900	4,6-3,8	3x230-240/400-415	2900	85,9	0,89-0,87	7,70/4,45	8,5-9,3
4,0	3x380-480	2900	8,1-6,6	3x230-240/400-415	2900	88,1	0,87	13,6/7,9	10-11,1
5,5	3x380-480	2900	11,0-8,8	3x230-240/400-415	2900	89,2	0,87-0,82	11,0	10,8-11,8
7,5	3x380-480	2900	14,8-11,6	3x230-240/400-415	2900	90,4	0,88-0,82	14,4-14,0/8,3-8,1	7,8-9,1
11,0	3x380-480	2900	22,5-18,8	3x230-240/400-415	2900	91,2	0,88-0,84	20,8-19,8/12,0-11,8	6,6-7,8
15,0	3x380-480	2900	30-26,0	3x230-240/400-415	2900	91,9	0,89-0,87	28,0-26,0/16,2-15,6	6,6-7,8
18,5	3x380-480	2900	37-31,0	3x230-240/400-415	2900	92,4	0,90-0,89	34,0-31,0/19,6-18,8	7,1-8,5
22,0	3x380-480	2900	43,5-35,0	3x230-240/400-415	2900	92,7	0,9	39,5/22,8	8,3
30,0	-	-	-	3x230-240/400-415	2900	93,5	0,88	55,0-51,0/31,5-30,0	7,0

Silniki pomp:

PTe - o regulowanej prędkości obrotowej

PT - stałobrotowe